

**7** 7 Years  
Product Warranty  
UK Only

**2** 2 Years  
On-Site Warranty  
Main-land UK Only



# Batten UEM 2 in 1

BEM303/SST BEM303/SST

## BEM Duo 3W Manual/Self test emergency module for Kosnic

- Select manual or self-test mode via the dual-mode DIP switch
- To adjust green LED indicator brightness, press and hold the test button for more than 3 seconds
- To set the duration test interval, press the push switch twice
- For maintained or non-maintained emergency lighting systems
- Automatic Self-test conforming to BS-EN-62034
- Designed for easy installation and battery replacement
- Internal LiFePO4 battery with improved lifespan
- With patented adaptive current control, this emergency module is suitable for LED load with a forward voltage between 30 to 300V

### Overview

The Emergency Module for LED

Batten Luminaires has been

designed for easy installation in a

range of Kosnic LED batten

luminaires. The emergency module

will adjust the output within the

module's limits to the level required

to operate the luminaire and ensure

an operation time of three hours.



### General Information

Installation  
Area

Internal

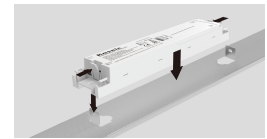

### Technical Summary

Product Code

BEM303/SST

Tel: 01635 523 713

Email: [sales@kosnic.com](mailto:sales@kosnic.com)

[Kosnic.com](http://Kosnic.com)



Kosnic Lighting KosnicUK

KosnicLightingUK

**7** 7 Years  
Product Warranty  
UK Only

**2** 2 Years  
On-Site Warranty  
Main-land UK Only

# Batten UEM 2 in 1



BEM303/SST

## Accessories

Product Code	Description	Type
BATS20LFP2	Battery LiFePO4 for Batten UEM Duo	Battery

## Overview

The Emergency Module for LED Batten Luminaires has been designed for easy installation in a range of Kosnic LED batten luminaires. The emergency module will adjust the output within the module's limits to the level required to operate the luminaire and ensure an operation time of three hours.



## General Information

Installation Area Internal

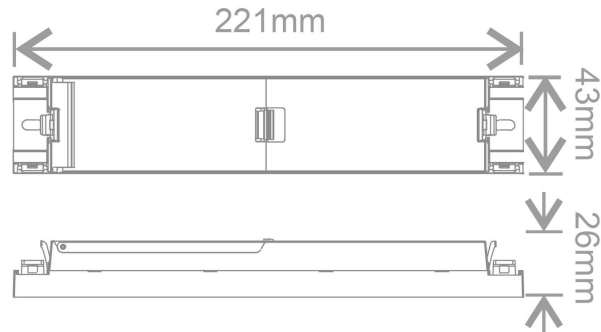

Tel: 01635 523 713

Email: [sales@kosnic.com](mailto:sales@kosnic.com)

[Kosnic.com](http://Kosnic.com)



Kosnic Lighting KosnicUK KosnicLightingUK KosnicUK