

7 7 Years
Product Warranty
UK Only

2 2 Years
On-Site Warranty
Main-land UK Only

Onyx DALI

08974 ONY05/DA

Onyx DALI-2 4W non-maintained high bay emergency

- Non-Maintained, 3hrs
- Push-wire loop-in and loop-out terminal block included
- Easy to install on LED high bay with eyebolt
- Built-in green status indicator
- DALI-2 conforming to EN 62386-202

Overview

The Onyx add-on emergency light for LED high bay luminaires available in 2 in 1 standard & self-test or DALI versions is suitable for installation on high bays with an eyebolt. It provides an emergency operation time of three hours giving you complete peace of mind in your lighting design.



General Information

IP Rating	IP65
Materials	Housing: Polycarbonate + Powder coated stainless steel
Installation Area	Internal and External
UEM/EME Protection	Class II

Technical Summary

Product Code	ONY05/DA
Lumens Output Maximum	600 lm
Emergency Luminous Flux	600 lm
UEM/EME Input Voltage	220-240Vac 50/60Hz
UEM/EME Ambient Temperature Range	0°C to 50°C
UEM/EME CCT	5,000 K
UEM/EME Input Power (Max)	4 W
UEM/EME Protection	Class II
UEM/EME Dimensions (L x W x D) (mm)	242x110x30 (293x62) see line drawing
Beam Angle - Lumi (°)	45

Compliance

Others	UKCA, CE, RoHS, WEEE, REACH
--------	-----------------------------

Tel: 01635 523 713

Email: sales@kosnic.com

Kosnic.com



Kosnic Lighting KosnicUK KosnicLightingUK

7 7 Years
Product Warranty
UK Only

2 2 Years
On-Site Warranty
Main-land UK Only

Onyx DALI



08974 ONY05/DA

Accessories

Product Code	Description	Type
BATS40LFP2	Battery LiFePO4, 4000mAh capacity, 6.4V Voltage	Battery

Overview

The Onyx add-on emergency light for LED high bay luminaires available in 2 in 1 standard & self-test or DALI versions is suitable for installation on high bays with an eyebolt. It provides an emergency operation time of three hours giving you complete peace of mind in your lighting design.

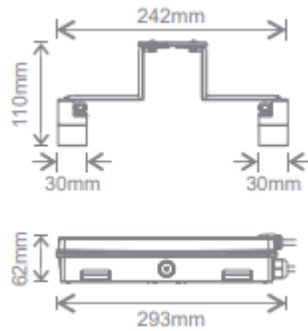

General Information

IP Rating	IP65
Materials	Housing: Polycarbonate + Powder coated stainless steel
Installation Area	Internal and External
UEM/EME Protection	Class II

LED Indicator

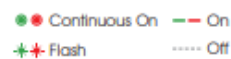
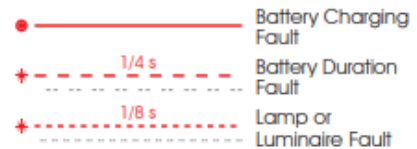
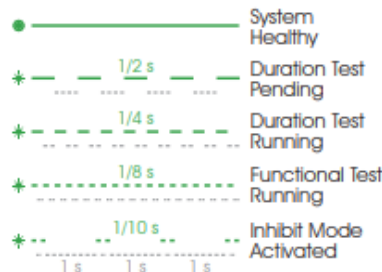

Tel: 01635 523 713

Email: sales@kosnic.com

Kosnic.com



Kosnic Lighting KosnicUK KosnicLightingUK KosnicUK