

**7** 7 Years  
Product Warranty  
UK Only

**2** 2 Years  
On-Site Warranty  
Main-land UK Only



# Batten UEM 2 in 1

08961 BEM303-LO/SST

## BEM LowTemp. Duo 2.5W Manual&Self-test for Kosnic Battens

- Can be used in ultra-low temperature environment
- To set the duration test interval, press the push switch twice
- Select manual or self-test mode via the dual-mode DIP switch
- To adjust green LED indicator brightness, press and hold the test button for more than 3 seconds
- For maintained or non-maintained emergency lighting systems
- Automatic Self-test conforming to BS-EN-62034
- Designed for easy installation and battery replacement
- With patented adaptive current control, this emergency module is suitable for LED load with a forward voltage between 30 to 300V
- Internal LiFePO4 battery with improved lifespan

### Overview

The Emergency Module for LED Batten Luminaires has been designed for easy installation in a range of Kosnic LED batten luminaires. The emergency module will adjust the output within the module's limits to the level required to operate the luminaire and ensure an operation time of three hours.

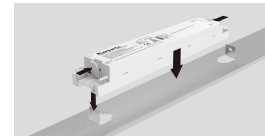

### General Information

IP Rating	IP20
Installation Area	Internal
UEM/EME Protection	Class II

### Technical Summary

Product Code	BEM303-LO/SST
Weight	0.18Kg
Dimensions (L x W x D) (mm)	221x43x26
UEM/EME Battery Life	4 y
UEM/EME Input Voltage	220-240Vac 50/60Hz
UEM/EME Ambient Temperature Range	-20°C to 50°C
UEM/EME Test Function	Automatic and Manual
UEM/EME Protection	Class II
UEM/EME Dimensions (L x W x D) (mm)	221x43x26

### Compliance

Others	UKCA, CE, RoHS, WEEE, REACH
--------	-----------------------------

Tel: 01635 523 713

Email: sales@kosnic.com

Kosnic.com



Kosnic Lighting KosnicUK KosnicLightingUK

**7** 7 Years  
Product Warranty  
UK Only

**2** 2 Years  
On-Site Warranty  
Main-land UK Only



# Batten UEM 2 in 1

08961 BEM303-LO/SST

## Accessories

Product Code	Description	Type
BATS16LFP2	Battery 6.4V LiFePO4, Temp. Sensor for Batten UEM Low Temp. 2 in 1	Battery

## Overview

The Emergency Module for LED Batten Luminaires has been designed for easy installation in a range of Kosnic LED batten luminaires. The emergency module will adjust the output within the module's limits to the level required to operate the luminaire and ensure an operation time of three hours.



## General Information

IP Rating	IP20
Installation Area	Internal
UEM/EME Protection	Class II

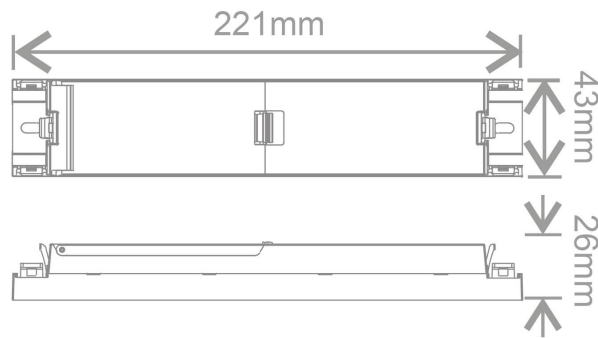

Tel: 01635 523 713

Email: sales@kosnic.com

Kosnic.com



Kosnic Lighting   KosnicUK   KosnicLightingUK   KosnicUK