

# Trent On-Site 2

08916 SIT22F20-W40

## Trent On Site 2 2ft non corrosive 12/15/20W 4000K

- High efficiency up to 135lm/W
- Optional plug-in ON/OFF sensor compatible with Uni-Remote
- Switchable wattage
- Optional plug-in emergency module
- 100-120V input for work site application only
- Suitable through wiring
- IP65 and vandal resistant (IK08)



### Overview

The Kosnic Trent On-Site non-corrosive LED battens are for use on a 100-110V supply for worksite applications. The 4ft and 5ft versions are also available with a built-in emergency module. The two available stands include a 5 meter extension cable with a yellow CEE 3-pin plug and two 110V socket outlets.



**IP65**



### General Information

IK Rating	IK08
IP Rating	IP65
Materials	Housing: ABS + PC
Protection Rating	Class I
Installation Area	Internal and External
L80B10 Lifetime (h) @Ta 25 °C	51,000 h

Technical Summary	
Product Code	SIT22F20-W40
Input Voltage Supply	100-120Vac 50/60Hz
Settable Wattages	12W, 15W, 20W
Power Factor	0.9
Default CCT	4,000 K
CRI	82
Dimmable	N
Lumens Output Maximum	2,500 lm
L80B10 Lifetime (h) @Ta 25 °C	51,000 h
Weight	1Kg
Dimensions (L x W x D) (mm)	589x86x80
LS Energy Efficiency Class	D

### Compliance

LVD	EN 60598-1:2024, EN 60598-2-1:2021, EN 62493:2015+A1:2022
EMC	EN 55015:2019+A11:2020, EN 61000-3-2:2019+A1:2021, EN 61000-3-3:2013+A1:2019+A2:2021, EN 61547:2023
Others	UKCA, CE, RoHS, WEEE

Tel: 01635 523 713

Email: [sales@kosnic.com](mailto:sales@kosnic.com)

[Kosnic.com](http://Kosnic.com)



Kosnic Lighting KosnicUK KosnicLightingUK

# Trent On-Site 2

08916 SIT22F20-W40

## Optional Gear

Product Code	Description	Type
HON-M	Hontza Plug in microwave motion & daylight sensor	Microwave Sensor
BEM303-110/SST	BEM Low Input Voltage Duo 3W Std&Self-test for Kosnic Battens	

## Accessories

Product Code	Description	Type
RMT-UNI	Universal Remote Control for Kosnic motion sensors	Remote Control
SUS-BTN04	Suspension for Niva Kasai Kennet Milo Congo Trent Avon Indus, 4 wires included, max. 1m drop	Suspension Kit
SUS-BTN04/25	Batten Suspension Kits 2.5m length, 4 wires included	Suspension Kit

Rated Power (W)	Lumen (lm)
12	1620
15	1950
20	2500

## Overview

The Kosnic Trent On-Site non-corrosive LED battens are for use on a 100-110V supply for worksite applications. The 4ft and 5ft versions are also available with a built-in emergency module. The two available stands include a 5 meter extension cable with a yellow CEE 3-pin plug and two 110V socket outlets.



**IP65**



## General Information

IK Rating	IK08
IP Rating	IP65
Materials	Housing: ABS + PC
Protection Rating	Class I
Installation Area	Internal and External

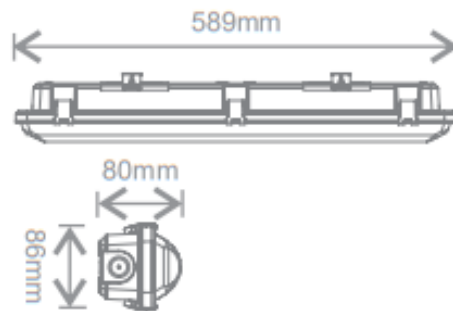

Tel: 01635 523 713

Email: sales@kosnic.com

Kosnic.com

