

7 7 Years
Product Warranty
UK Only

2 2 Years
On-Site Warranty
Main-land UK Only



Nimbo

08855 NIM60AL-SCT/DA

Nimbo circular highbay 15/25/40/60W 3000K/4000K

- High efficiency up to 140lm/W
- DALI dimming alternative driver available
- Switchable wattage and CCT (300/4000K)
- Available in PC or aluminium shade
- Diecast aluminium
- Vandal resistant (IK08)
- Reflector included
- Low glare, UGR < 19 for 15W/25W outputs, UGR < 22 for 40W/60W outputs

Overview

Nimbo High Bay Luminaire is designed for use in general industrial areas, manufacturing, warehousing, leisure facilities and retail environments.

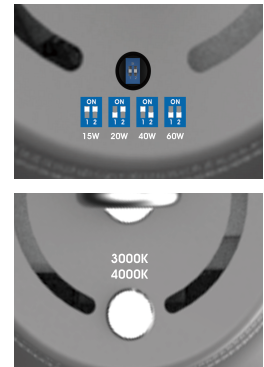

General Information

Ambient Temperature Range (°C)	-20°C to 50°C
IK Rating	IK08
IP Rating	IP20
Materials	Housing Aluminium, PC
Protection Rating	Class I
Installation Area	Internal and External
L80B10 Lifetime (h) @Ta 25 °C	54,000 h

Compliance

LVD	EN 60598-1:2024, EN 60598-2-1:2021, EN 62493:2015+A1:2022
EMC	EN 55015:2019+A11:2020, EN 61000-3-2:2019+A1:2021, EN 61000-3-3:2013+A1:2019+A2:2021, EN 61547:2023
Others	UKCA, CE, RoHS, WEEE

Technical Summary

Product Code	NIM60AL-SCT/DA
Input Voltage Supply	220-240Vac 50/60Hz
Inrush Current (peak/duration) (A)	120A /195us
Settable Wattages	15W, 25W, 40W, 60W
Driver Code/Part number	Sosen
Power Factor	>0.90
Settable Colour Temperatures	3000K, 4000K
SDCM of CCT	<6
CRI	82
Dimmable	N
Flicker	<1%
Lumens Output Maximum	8,400 lm
Maximum Efficiency	140 lm/W
Maintained Luminous Flux	250 lm
L70B50 Lifetime (h) @Ta 25 °C	54,000 h
L80B10 Lifetime (h) @Ta 25 °C	54,000 h
L90B10 Lifetime (h) @Ta 25 °C	31,000 h
Nominal Lifetime (h)	50,000 h
Glow wire temperature(°C)	650
Blue Light Hazard	RG1
Weight	2kg
Dimensions (L x W x D) (mm)	456xØ330
Beam Angle - Lumi (°)	90
LS Energy Efficiency Class	D

Tel: 01635 523 713

Email: sales@kosnic.com

Kosnic.com



Kosnic Lighting KosnicUK KosnicLightingUK

7 Years
Product Warranty
UK Only

2 Years
On-Site Warranty
Main-land UK Only

Nimbo



08855 NIM60AL-SCT/DA

Overview

Nimbo High Bay Luminaire is designed for use in general industrial areas, manufacturing, warehousing, leisure facilities and retail environments.

Rated Power (W)	Current (mA)	CCT (k)	Luminous Flux (lm)	UGR	Power Factor
15	87	3000 Warm White	1800	<19	0.75
15	87	4000 Cool White	1950	<19	0.75
25	125	3000 Warm White	3300	<19	0.82
25	125	4000 Cool White	3500	<19	0.825
40	185	3000 Warm White	5200	<22	0.94
40	185	4000 Cool White	5600	<22	0.94
60	275	3000 Warm White	7800	<22	0.95
60	275	4000 Cool White	8400	<22	0.95



IP20



General Information

Ambient Temperature Range (°C)	-20°C to 50°C
IK Rating	IK08
IP Rating	IP20
Materials	Housing Aluminium, PC
Nominal Lifetime (h)	50,000 h
Protection Rating	Class I
Installation Area	Internal and External

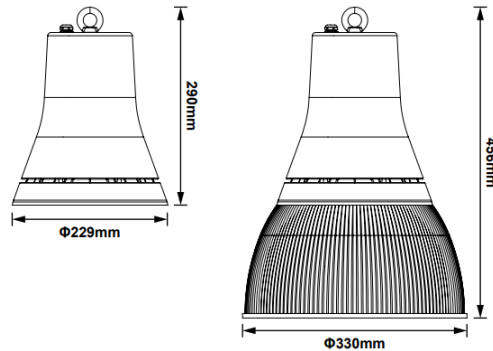

Tel: 01635 523 713

Email: sales@kosnic.com

Kosnic.com



Kosnic Lighting KosnicUK KosnicLightingUK KosnicUK