

**7** 7 Years  
Product Warranty  
UK Only

**2** 2 Years  
On-Site Warranty  
Main-land UK Only



# Echo III

07405 ECH3100-W50

## Echo III, LED Circular Highbay, IP65, 100W, 5000K

- High efficiency of 145lm/W
- Diecast aluminium
- Dimmable via a wired 1-10v dimmer switch
- IP65 & vandal resistant (IK10)
- Optional reflectors on all models
- Flicker free



## Overview

The Echo III provides a high efficiency of 145lm/W or a range of wattage options and 1-10v dimming for further control. The IP65 rating and range of shades means the Echo III is suited for a range of areas both internal and external, with optional emergency gear if needed.



**IP65**



## General Information

Ambient Temperature Range (°C)	-20°C to 50°C
IK Rating	IK10
IP Rating	IP65
Nominal Lifetime (h)	50,000 h
Protection Rating	Class I
Installation Area	Internal and External

## Technical Summary

Product Code	ECH3100-W50
Input Voltage Supply	220-240Vac 50/60Hz
Default Power	100 W
Driver Code/Part number	Sosen
Power Factor	0.96
Default CCT	5,000 K
SDCM of CCT	<6
CRI	≥82
Dimmable	N
Flicker	<1%
Lumens Output Maximum	15,000 lm
Maximum Efficiency	150 lm/W
Emergency Luminous Flux	900 lm
L80B10 Lifetime (h) @Ta 25 °C	54,000 h
Nominal Lifetime (h)	50,000 h
Weight	2.6Kg
Dimensions (L x W x D) (mm)	164xØ259



Kosnic Lighting



KosnicUK



KosnicLightingUK



KosnicUK

Tel: 01635 523 713

Email: [sales@kosnic.com](mailto:sales@kosnic.com)

[Kosnic.com](http://Kosnic.com)

**7** 7 Years  
Product Warranty  
UK Only

**2** 2 Years  
On-Site Warranty  
Main-land UK Only

# Echo III



07405 ECH3100-W50

## Overview

The Echo III provides a high efficiency of 145lm/W or a range of wattage options and 1-10v dimming for further control. The IP65 rating and range of shades means the Echo III is suited for a range of areas both internal and external, with optional emergency gear if needed.



## General Information

Ambient Temperature Range (°C)	-20°C to 50°C
IK Rating	IK10
IP Rating	IP65
Nominal Lifetime (h)	50,000 h
Protection Rating	Class I
Installation Area	Internal and External

## Optional Gear

Product Code	Description	Type
EMHB08/ST	8W self-test Universal Emergency Module for LED high bay	Self-test Emergency Module
EMHB08	8W standard Universal Emergency Module for LED high bay	Emergency Module
EMHB10	10W standard Universal Emergency Module for LED high bay	Emergency Module
EMHB10/ST	10W self-test Universal Emergency Module for LED high bay	Self-test Emergency Module
ECH-RMT	Echo II PIR sensor remote control (for PIR-ZGA)	Remote Control
PIR-ZGA	PIR sensor with Zhaga connector with ON/OFF 0-10V Dimming	PIR Sensor
EMHB10/DA	10W DALI Emergency Module for Kosnic LED high bay	Emergency Module

## Accessories

Product Code	Description	Type
ECH-SHD-PCS	Echo PC bell-shaped shade for KHBE100C1	Shade

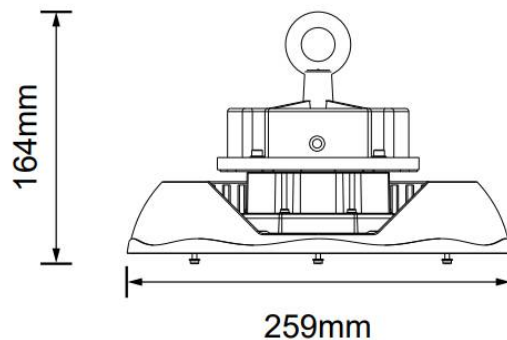

Kosnic Lighting



KosnicUK



KosnicLightingUK



KosnicUK

Tel: 01635 523 713

Email: sales@kosnic.com

Kosnic.com