

5 5 Years
Product Warranty
UK Only

3 3 Years
On-Site Warranty
Main-land UK Only



DD 2 Sensor

06370 DD18CRD/4P-SCT

LED DD Integrated Motion Sensor, 18W, 4pin CCT switchable

- Colour temperature switchable 2700K/4000K/6500K
- Replacement for 16w, 28w, 38w fluorescent DD
- Save energy by up to 65%
- lamps used with magnetic ballast
- Compatible with Kosnic emergency module for instant conversion
- Flicker free

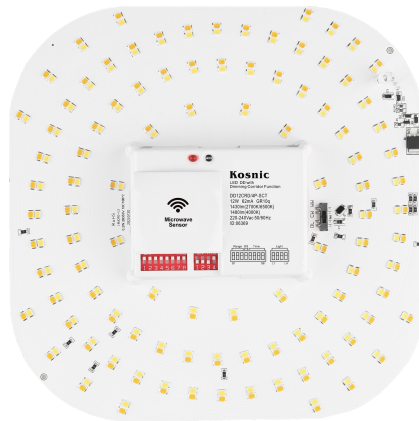

Overview

The Kosnic range of LED DD lamps takes a fresh approach to functional lighting with a design philosophy offering plug-in emergency packs and optional microwave sensor versions so that there are no barriers to retrofitting LEDs in commercial fittings. The products bring the energy saving capabilities of LED technology to the



General Information

Ambient Temperature Range (°C)	-20°C to 40°C
Installation Area	Internal
L80B10 Lifetime (h) @Ta 25 °C	54,000 h

Compliance

LVD	EN 62031:2020, EN 62493:2015+A1:2022, EN 62560:2012+A11:2019
EMC	EN 55015:2019+A11:2020, EN 61000-3-2:2019+A1:2021, EN 61000-3-3:2013+A1:2019+A2:2021, EN 61547:2023
Others	UKCA, CE, RoHS, WEEE

Technical Summary

Product Code	DD18CRD/4P-SCT
Input Voltage Supply	220-240Vac 50/60Hz
Default Power	18 W
Power Factor	0.86
Settable Colour Temperatures	2700K, 4000K, 6500K
CRI	83
Dimmable	N
Lumens Output Maximum	2,200 lm
Maximum Efficiency	122 lm/W
L70B50 Lifetime (h) @ Ta 25 °C	54,000 h
L80B10 Lifetime (h) @ Ta 25 °C	54,000 h
L90B10 Lifetime (h) @ Ta 25 °C	42,000 h
Nominal Lifetime (h)	30,000 h
Glow wire temperature(°C)	650
Blue Light Hazard	RG1
Weight	0.2Kg
Dimensions (L x W x D) (mm)	38xØ192
LS Energy Efficiency Class	E

Tel: 01635 523 713

Email: sales@kosnic.com

Kosnic.com



Kosnic Lighting KosnicUK KosnicLightingUK

5 5 Years
Product Warranty
UK Only

3 3 Years
On-Site Warranty
Main-land UK Only

DD 2 Sensor

06370 DD18CRD/4P-SCT

Accessories

Product Code	Description	Type
DDLAMPHLD	LED DD Lamp holder for 4pin GR10q	Housing
Settable (Default in Bold)	Variable	
Rated Power (W)	CCT (K)	Total Luminous Flux (lm)
18	2700	2100
18	4000	2200
18	6500	2100

Overview

The Kosnic range of LED DD lamps takes a fresh approach to functional lighting with a design philosophy offering plug-in emergency packs and optional microwave sensor versions so that there are no barriers to retrofitting LEDs in commercial fittings. The products bring the energy saving capabilities of LED technology to the



General Information

Ambient Temperature Range (°C)	-20°C to 40°C
Nominal Lifetime (h)	30,000 h
Installation Area	Internal

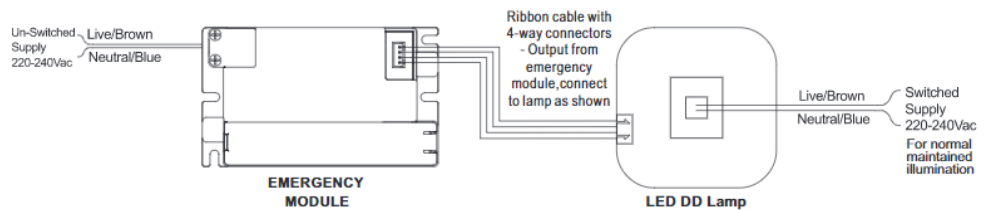
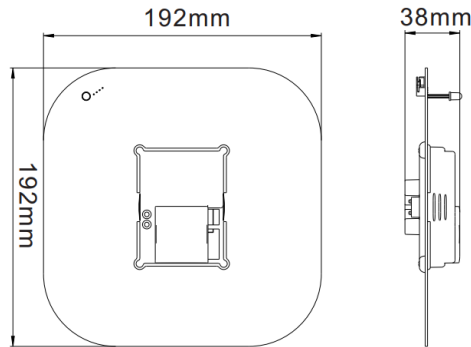

Tel: 01635 523 713

Email: sales@kosnic.com

Kosnic.com

