

5 5 Years
Product Warranty
UK Only

3 3 Years
On-Site Warranty
Main-land UK Only



DD II Standard

06367 DD18/4P-SCT

LED DD Standard, 18W, 4pin, 30000hrs CCT

- Colour temperature switchable 2700K/4000K/6500K
- Replacement for 16w, 28w, 38w fluorescent DD
- Save energy by up to 65%
- lamps used with magnetic ballast
- Compatible with Kosnic emergency module for instant conversion
- Flicker free



Overview

The Kosnic range of LED DD lamps takes a fresh approach to functional lighting with a design philosophy offering plug-in emergency packs and optional microwave sensor versions so that there are no barriers to retrofitting LEDs in commercial fittings. The products bring the energy saving capabilities of LED technology to the



General Information

Ambient Temperature Range (°C)	-20°C to 40°C
Nominal Lifetime (h)	30,000 h
Installation Area	Internal

Technical Summary

Product Code	DD18/4P-SCT
Input Voltage Supply	220-240Vac 50/60Hz
Default Power	18 W
Power Factor	0.94
Default CCT	4,000 K
Settable Colour Temperatures	2700k, 4000k, 6500k
CRI	81
Dimmable	N
Lumens Output Maximum	2,400 lm
Maximum Efficiency	133 lm/W
L80B10 Lifetime (h) @Ta 25 °C	54,000 h
Nominal Lifetime (h)	30,000 h
Weight	0.150Kg
Dimensions (L x W x D) (mm)	33xØ192



Kosnic Lighting



KosnicUK



KosnicLightingUK



KosnicUK

Tel: 01635 523 713

Email: sales@kosnic.com

Kosnic.com

5 5 Years
Product Warranty
UK Only

3 3 Years
On-Site Warranty
Main-land UK Only

DD II Standard



06367 DD18/4P-SCT

Accessories

Product Code	Description	Type
DDLAMPHLD	LED DD Lamp holder for 4pin GR10q	Housing

Settable (Default in Bold)	Variable	
Rated Power (W)	CCT (K)	Total Luminous Flux (lm)
18	2700	2210
18	4000	2400
18	6500	2210

Overview

The Kosnic range of LED DD lamps takes a fresh approach to functional lighting with a design philosophy offering plug-in emergency packs and optional microwave sensor versions so that there are no barriers to retrofitting LEDs in commercial fittings. The products bring the energy saving capabilities of LED technology to the



General Information

Ambient Temperature Range (°C)	-20°C to 40°C
Nominal Lifetime (h)	30,000 h
Installation Area	Internal

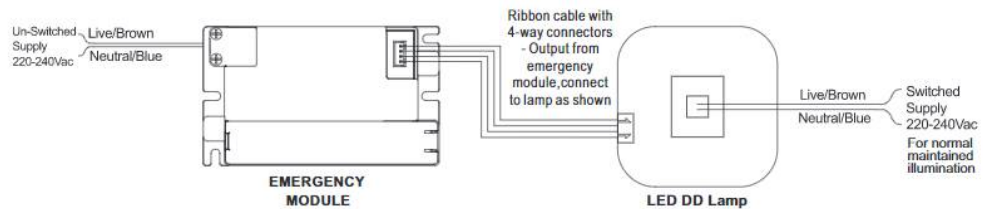
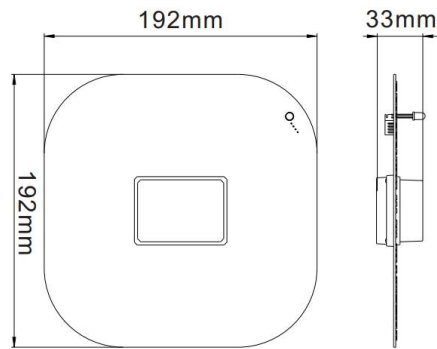

Kosnic Lighting



KosnicUK



KosnicLightingUK



KosnicUK

Tel: 01635 523 713

Email: sales@kosnic.com

Kosnic.com