

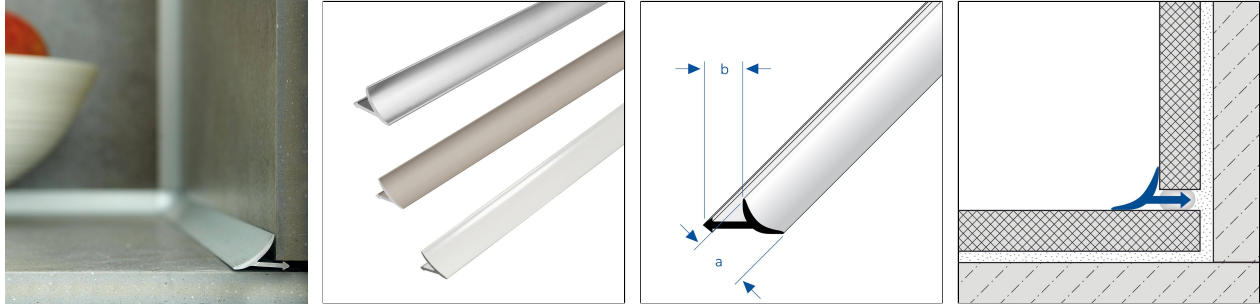

T-COVE

Concave trim for wall/floor connection



TECHNICAL DIMENSIONS AND PRODUCT VARIANTS

| | |
|-------------|---|
| Material | [Aluminium] |
| Surface | [anodised], [brushed],[high-gloss anodised], [high-gloss anodised], [anodised],[brushed], [powder coated] |
| Colour | black, silver, titanium, bronze, white, black matt (RAL 9005) |
| Length | 250 cm |
| sight width | 12 mm, 16 mm, 22 mm |
| Height | 11.5 mm, 9 mm, 18 mm |
| Width mm | 16.5 mm, 14 mm, 18 mm |

PRODUCT VARIANTS

| Ident | Height | Surface | Colour | Length |
|-------------------|---------|------------------------------|-----------------------|--------|
| TCAE 120/250 | 9 mm | anodised | silver | 250 cm |
| TCAE 120-T/250 | 9 mm | anodised | titanium | 250 cm |
| TCA 1262/250 | 9 mm | high-gloss anodised | silver | 250 cm |
| TCAC 1230/250 | 9 mm | powder coated | white | 250 cm |
| | 11.5 mm | anodised | black | 250 cm |
| TCAE 160/250 | 11.5 mm | anodised | silver | 250 cm |
| TCAE 160-T/250 | 11.5 mm | anodised | titanium | 250 cm |
| TCAE 160-B-SF/250 | 11.5 mm | anodised, brushed | bronze | 250 cm |
| TCA 1662-SF/250 | 11.5 mm | brushed, high-gloss anodised | silver | 250 cm |
| TCA 1663-SF/250 | 11.5 mm | brushed, high-gloss anodised | titanium | 250 cm |
| TCA 1662/250 | 11.5 mm | high-gloss anodised | silver | 250 cm |
| TCA 1663/250 | 11.5 mm | high-gloss anodised | titanium | 250 cm |
| TCACM 1611/250 | 11.5 mm | powder coated | black matt (RAL 9005) | 250 cm |
| TCAC 1630/250 | 11.5 mm | powder coated | white | 250 cm |
| TCAE 220/250 | 18 mm | anodised | silver | 250 cm |
| TCAE 220-T/250 | 18 mm | anodised | titanium | 250 cm |
| TCA 2262/250 | 18 mm | high-gloss anodised | silver | 250 cm |
| TCAC 2230/250 | 18 mm | powder coated | white | 250 cm |

Data sheet Accessories

Please note: For technical reasons, tolerances in color effects of the materials and print are possible. All information is based on the best of our knowledge and belief. No guarantee can be derived from this. We reserve the right to any technical changes if they are in the interest of progress or if they are production-related.



Matching end caps are available as accessories

MATERIAL

Aluminium can be used wherever a medium mechanical stresses are expected. Contact with alkaline materials (e.g. tile adhesive) can lead to discolouration, which can be difficult to remove afterwards. High humidity during the drying phase can intensify this process. Always wipe off tile adhesive or grout on visible surfaces immediately with plenty of water, then wipe dry and ensure that the room is well ventilated.

Suitability in terms of mechanical and chemical resistance must always be checked on a case-by-case basis.

PROCESSING

1. Ensure the wall /floor junction is clean and free of debris (at least 5 mm deep).
2. Inject the wall/floor junction with an elastic sealing material (SPEED-FLEX or similar).
3. Press in the centre bar of the profile until the profile is firmly adhered to the surfaces on both sides.
4. Use the matching internal and external corner pieces available as accessories to form corners. In terms of installation, the internal or external corner pieces should be fitted first, then the profile should be fully installed without leaving a joint.
5. Close the open ends with the appropriate end caps.

The generally recognised rules of technology must be observed. The suitability with regard to mechanical and chemical resistance must always be checked in each individual case.

CARE

Aluminium does not require any special care. If necessary, it can simply be damp-cleaned with clear, clean water and a few drops of washing-up liquid. Then wipe dry.

Acidic, alkaline and abrasive cleaning agents should be avoided.

Please note: For technical reasons, tolerances in color effects of the materials and print are possible.
All information is based on the best of our knowledge and belief. No guarantee can be derived from this.
We reserve the right to any technical changes if they are in the interest of progress or if they are production-related.