

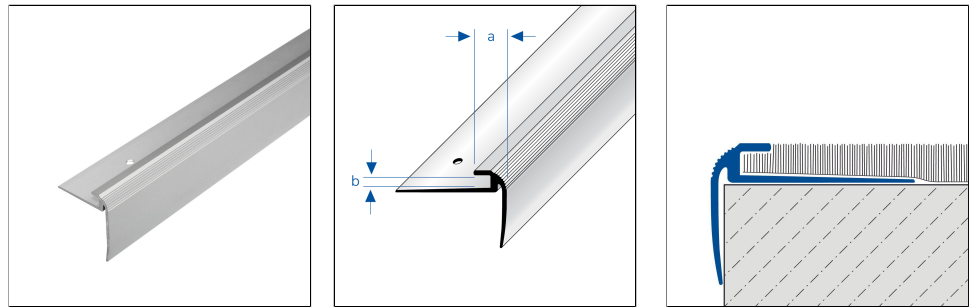

TEKA Step TK

Push-In Step Trim With Anti-Slip Surface Made Of Aluminium



MATERIAL

Aluminium can be used wherever medium mechanical stress is expected. Contact with alkaline materials (e.g. tile adhesive) can cause discolouration that is difficult to remove.

The suitability with regard to mechanical and chemical resistance must always be checked in each individual case.

CARE

Aluminium does not require any special care. If necessary, it can be cleaned with clear, clean water and a few drops of washing-up liquid. Then wipe dry. Acidic and abrasive cleaning agents should be avoided.

PROCESSING

1. Place the profile on the substrate and align it.
2. Fix the profile to the substrate using sufficiently dimensioned dowels/screws.
3. Cut the profile at an angle to form corners. Seal the mitre joint with a neutral cross-linked silicon.
4. Before inserting the safety inserts, clean the adhesive surfaces and remove any substances that could impair adhesion.

The generally accepted rules of technology and tiling must be observed. Suitability for use with mechanical and chemical resistance must always be checked in each individual case.

TECHNICAL DIMENSIONS AND PRODUCT VARIANTS

Please note: For technical reasons, tolerances in color effects of the materials and print are possible. All information is based on the best of our knowledge and belief. No guarantee can be derived from this. We reserve the right to any technical changes if they are in the interest of progress or if they are production-related.

DURAL GmbH | Südring 11 | D-56412 Ruppach-Goldhausen | Germany | +49 2602/9261-0 | info@dural.com

DURAL Ltd. | Unit 6a | Wakefield Business Centre Denby Dale Rd | Wakefield | WF2 7AZ | United Kingdom | ukinfo@dural.com

The recognised standards and regulations of technology must be observed. Previous data sheets are invalid.

www.dural.com



Material	[Aluminium]
Surface	[anodised]
Colour	silver
Length	270 cm
sight width	10 mm
Height	5 mm
Width mm	32 mm
height 2	24 mm

PRODUCT VARIANTS

Ident	Height	Surface	Colour	Length
TAE 50-TK/270	5 mm	anodised	silver	270 cm

Please note: For technical reasons, tolerances in color effects of the materials and print are possible.
 All information is based on the best of our knowledge and belief. No guarantee can be derived from this.
 We reserve the right to any technical changes if they are in the interest of progress or if they are production-related.