

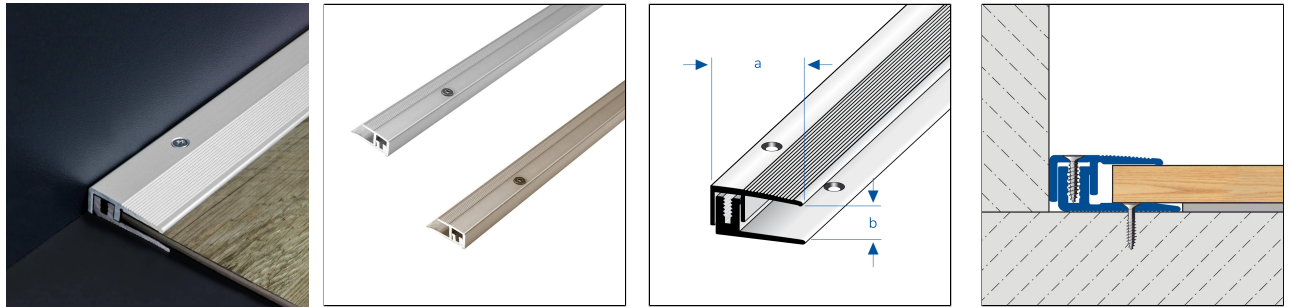

# DUOFLOOR LVT Border

Screwable metal edge trim profile



## PROPERTIES

Basic trim for screw mounting for covering heights 3.5 - 5 mm

Top profile for screwing

Includes fastening material

## MATERIAL

Aluminium can be used wherever medium mechanical stress is to be expected. Contact with alkaline materials (e.g. tile adhesive) can lead to discolouration, which is difficult to remove afterwards. High humidity can intensify this process. Dirt deposits can be removed with standard cleaning agents. Cleaning agents must be free of scouring powder or aggressive additives.

The suitability with regard to mechanical and chemical resistance must always be checked in each individual case.

## CARE

Aluminium does not require any special care. If necessary, it can be cleaned with clear, clean water and a drop of washing-up liquid. Then wipe dry.

Avoid using acidic, alkaline and abrasive cleaning agents.

## PROCESSING

1. Cut the profiles to size. Align the basic trim on the floor, mark it and mark the drill holes.
2. Secure the basic trim to the marked position using screws and dowels.
3. Lay the floor covering with sufficient expansion joint spacing.
4. Place the top profile on the basic trim.
5. Screw the top profile onto the basic trim.

The profile will adjust to the respective height.

The generally accepted rules of technology and tiling must be observed. Suitability for use with mechanical and chemical resistance must always be checked in each individual case..

Please note: For technical reasons, tolerances in color effects of the materials and print are possible. All information is based on the best of our knowledge and belief. No guarantee can be derived from this. We reserve the right to any technical changes if they are in the interest of progress or if they are production-related.

DURAL GmbH | Südring 11 | D-56412 Ruppach-Goldhausen | Germany | +49 2602/9261-0 | info@dural.com

DURAL Ltd. | Unit 6a | Wakefield Business Centre Denby Dale Rd | Wakefield | WF2 7AZ | United Kingdom | ukinfo@dural.com

The recognised standards and regulations of technology must be observed. Previous data sheets are invalid.

[www.dural.com](http://www.dural.com)



**TECHNICAL DIMENSIONS AND PRODUCT VARIANTS**

Material	[Aluminium]
Surface	[anodised]
Colour	silver, champagne, titanium
Length	100 cm, 270 cm
sight width	17 mm
Height	3.5 mm
height up to	5 mm

**PRODUCT VARIANTS**

Ident	Height	Surface	Colour	Length
DUFB LVT 17-600-C/100	3.5 mm	anodised	champagne	100 cm
DUFB LVT 17-600-C/270	3.5 mm	anodised	champagne	270 cm
DUFB LVT 17-600/100	3.5 mm	anodised	silver	100 cm
DUFB LVT 17- 600/270	3.5 mm	anodised	silver	270 cm
DUFB LVT 17-600-T/100	3.5 mm	anodised	titanium	100 cm
DUFB LVT 17-600-T/270	3.5 mm	anodised	titanium	270 cm

Please note: For technical reasons, tolerances in color effects of the materials and print are possible. All information is based on the best of our knowledge and belief. No guarantee can be derived from this. We reserve the right to any technical changes if they are in the interest of progress or if they are production-related.