

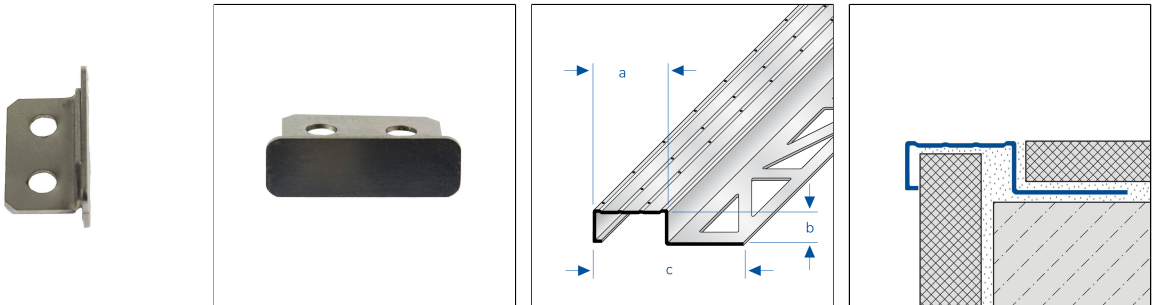

DURASTEP SOLID Stainless Steel (304)

End cap for stair nosing profile DURASTEP Solid. Can be used on the right and left.



TECHNICAL DIMENSIONS AND PRODUCT VARIANTS

Material	[Stainless Steel (304)]
Surface	[natural]
Colour	natural

PRODUCT VARIANTS

Ident	Surface	Colour
DSTOE-XK/10	natural	natural

MATERIAL

Stainless steel (V2A/304) is particularly suitable for areas of application subject to high mechanical loads and where particularly high demands are placed on cleanliness, hygiene and chemical resistance. Contact with products containing hydrochloric acid should be avoided.

Tools made of unalloyed steel must not be used during processing. Open cut edges are not rust-resistant. If necessary, separate rust protection must be applied there.

Depending on the environmental conditions, rust film may also form on stainless steel and should be removed immediately.

The usability in terms of mechanical and chemical resistance must always be checked on a case-by-case basis.

PROCESSING

1. Select the profile according to the tile thickness.

Please note: For technical reasons, tolerances in color effects of the materials and print are possible. All information is based on the best of our knowledge and belief. No guarantee can be derived from this. We reserve the right to any technical changes if they are in the interest of progress or if they are production-related.



- 2 Apply tile adhesive with a notched trowel.
- 3 Press the profile into the adhesive bed and align.
4. Fill over the entire surface of the fixing leg.
5. Press the tiles firmly into place and align them so that they are flush with the upper edge of the profile. Lay the tiles fully flush.
6. Use suitable inner or outer corner pieces.
7. Leave a joint of 1-2 mm to the profile.
8. Fill the space between the tiles and the profile completely with grout.

Protect visible surfaces from contact with tile adhesive or grout and, if necessary, clean immediately with a cloth and clean water. Then rub dry.

The generally recognised rules of technology must be observed. Suitability in terms of mechanical and chemical resistance must always be checked on a case-by-case basis.

CARE

Stainless steel (V2A/304) does not require any special care. If necessary, it can simply be cleaned with clear, clean water and a few drops of washing-up liquid. Then wipe dry.

Acidic and abrasive cleaning agents should be avoided. Flash rust can be removed with commercially available polishes suitable for stainless steel.

Please note: For technical reasons, tolerances in color effects of the materials and print are possible.
All information is based on the best of our knowledge and belief. No guarantee can be derived from this.
We reserve the right to any technical changes if they are in the interest of progress or if they are production-related.