

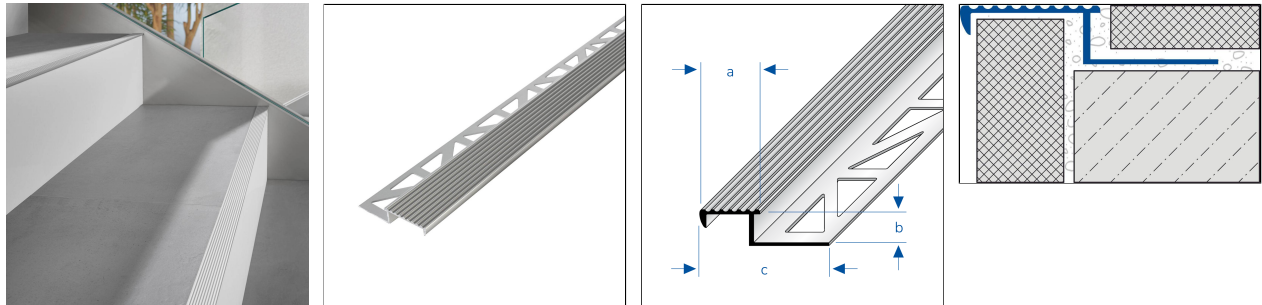

DURASTEP SOLID-L

Metal-Stair nosing profile

Slip resistance class R11 / V6



TECHNICAL DIMENSIONS AND PRODUCT VARIANTS

Material	[Aluminium]
Surface	[natural], [anodised]
Colour	natural, silver
Length	250 cm, 300 cm
sight width	30 mm
Height	9 mm, 11 mm, 22 mm

PRODUCT VARIANTS

Ident	Height	Surface	Colour	Length
DSTOAE 90-L/250	9 mm	anodised	silver	250 cm
DSTOAE 90-L/300	9 mm	anodised	silver	300 cm
DSTOA 90-L/250	9 mm	natural	natural	250 cm
DSTOA 90-L/300	9 mm	natural	natural	300 cm
DSTOAE 110-L/250	11 mm	anodised	silver	250 cm
DSTOAE 110-L/300	11 mm	anodised	silver	300 cm
DSTOA 110-L/250	11 mm	natural	natural	250 cm
DSTOA 110-L/300	11 mm	natural	natural	300 cm
DSTOAE 220-L/250	22 mm	anodised	silver	250 cm

Data sheet Accessories

Slip resistance class R11, displacement space V6

PROPERTIES

Slip resistance class R11, displacement space V6

MATERIAL

Aluminium can be used wherever medium mechanical stress is to be expected. Contact with alkaline materials (e.g. tile adhesive) can cause discolouration that is difficult to remove. High humidity during the drying phase can intensify this process. Always wipe tile adhesive or grout from visible surfaces immediately with plenty of water, then wipe dry and ensure good room ventilation.

The suitability with regard to mechanical and chemical resistance must always be checked on a case-by-case basis.

Please note: For technical reasons, tolerances in color effects of the materials and print are possible. All information is based on the best of our knowledge and belief. No guarantee can be derived from this. We reserve the right to any technical changes if they are in the interest of progress or if they are production-related.



PROCESSING

1. Select the profile according to the tile thickness.
2. Apply tile adhesive with a notched trowel.
3. Press the profile into the adhesive bed and align it.
4. Fill the fixing flange completely with adhesive.
5. Press the tiles firmly into place and align them so that they are flush with the top edge of the profile. Lay the tiles so that they are completely covered.
6. Cut the profile to mitre for corner formation. Seal the mitre joint with a neutral cross-linked silicon.
7. Leave a 1-2 mm joint between the profile and the tiles.
8. Fill the space between the tiles and the profile completely with joint mortar.

Protect visible surfaces from contact with tile adhesive or grout and clean immediately with a cloth and clear water if necessary. Then rub dry.

The generally accepted rules of technology and tiling must be observed. Suitability for use with mechanical and chemical resistance must always be checked in each individual case.

CARE

Aluminium does not require any special care. If necessary, it can be cleaned with clear, clean water and a few drops of washing-up liquid. Then wipe dry.

Avoid using acidic and abrasive cleaning agents.

Please note: For technical reasons, tolerances in color effects of the materials and print are possible.
All information is based on the best of our knowledge and belief. No guarantee can be derived from this.
We reserve the right to any technical changes if they are in the interest of progress or if they are production-related.