

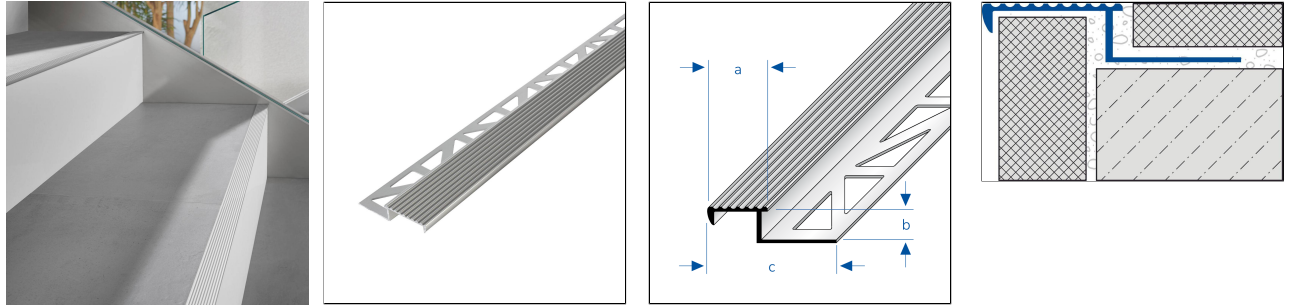

# DURASTEP SOLID-L

## Metal Stair Nosing Profile With Wide Tread Surface



### TECHNICAL DIMENSIONS AND PRODUCT VARIANTS

Material	Aluminium
Surface	natural, anodised
Colour	natural, silver
Length	250 cm, 300 cm
sight width	30 mm
Height (b)	9 mm, 11 mm, 22 mm

### MATERIAL

Aluminium can be used wherever a medium mechanical load-bearing capacity is to be expected. Contact with alkaline materials (e.g. tile adhesive) can lead to discolouration, which can hardly be removed afterwards. High humidity during the drying phase can intensify this process. Always wipe off tile adhesive or grout on visible surfaces immediately with plenty of water, then wipe dry and ensure that the room is well ventilated.

Suitability in terms of mechanical and chemical resistance must always be checked on a case-by-case basis.

### CARE

Aluminium does not require any special care. If necessary, it can simply be damp-cleaned with clear, clean water and a few drops of washing-up liquid. Then wipe dry.

Acidic and abrasive cleaning agents should be avoided.

### PROCESSING

1. Select the profile according to the tile thickness.
2. Apply tile adhesive with a notched trowel.
3. Press the profile into the adhesive bed and align.
4. Fill over the entire surface of the fixing leg.
5. Press the tiles firmly into place and align them so that they are flush with the upper edge of the profile. Lay the tiles fully flush.
6. Use suitable inner or outer corner pieces.
7. Leave a joint of 1-2 mm to the profile.

25 April 2025 07:04 PM

Please note: For technical reasons, tolerances in color effects of the materials and print are possible. All information is based on the best of our knowledge and belief. No guarantee can be derived from this. We reserve the right to any technical changes if they are in the interest of progress or if they are production-related.



8. Fill the space between the tiles and the profile completely with grout.

Protect visible surfaces from contact with tile adhesive or grout and, if necessary, clean immediately with a cloth and clean water. Then rub dry.

The generally recognised rules of technology must be observed. Suitability in terms of mechanical and chemical resistance must always be checked on a case-by-case basis.

**PRODUCT VARIANTS**

Ident	Height (b)	Surface	Colour	Length
DSTOAE 90-L/250	9 mm	anodised	silver	250 cm
DSTOAE 90-L/300	9 mm	anodised	silver	300 cm
DSTOA 90-L/250	9 mm	natural	natural	250 cm
DSTOA 90-L/300	9 mm	natural	natural	300 cm
DSTOAE 110-L/250	11 mm	anodised	silver	250 cm
DSTOAE 110-L/300	11 mm	anodised	silver	300 cm
DSTOA 110-L/250	11 mm	natural	natural	250 cm
DSTOA 110-L/300	11 mm	natural	natural	300 cm
DSTOAE 220-L/250	22 mm	anodised	silver	250 cm

25 April 2025 07:04 PM

Please note: For technical reasons, tolerances in color effects of the materials and print are possible. All information is based on the best of our knowledge and belief. No guarantee can be derived from this. We reserve the right to any technical changes if they are in the interest of progress or if they are production-related.

