

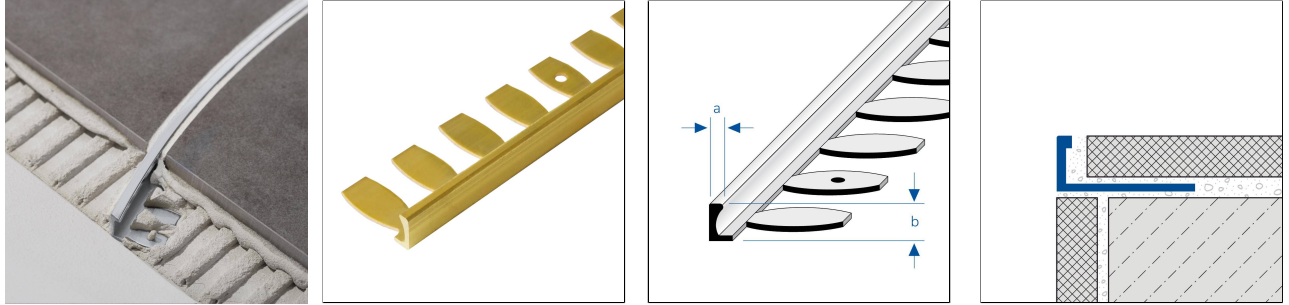

DUROSOL Brass Z-Flex



TECHNICAL DIMENSIONS AND PRODUCT VARIANTS

Material	Brass
Surface	natural
Colour	natural
Length	250 cm
Sichtbreite (a)	3 mm
Höhe (b)	12.5 mm, 3 mm, 18.5 mm, 6 mm, 8 mm, 10 mm, 11 mm, 15 mm, 20 mm

PRODUCT VARIANTS

Ident	Höhe (b)	Surface	Colour	Length
DSM 30-ZF/250	3 mm	natural	natural	250 cm
DSM 60-ZF/250	6 mm	natural	natural	250 cm
DSM 80-ZF/250	8 mm	natural	natural	250 cm
DSM 100-ZF/250	10 mm	natural	natural	250 cm
DSM 110-ZF/250	11 mm	natural	natural	250 cm
DSM 125-ZF/250	12.5 mm	natural	natural	250 cm
DSM 150-ZF/250	15 mm	natural	natural	250 cm
DSM 185-ZF/250	18.5 mm	natural	natural	250 cm
DSM 200-ZF/250	20 mm	natural	natural	250 cm

Please note: For technical reasons, tolerances in color effects of the materials and print are possible. All information is based on the best of our knowledge and belief. No guarantee can be derived from this. We reserve the right to any technical changes if they are in the interest of progress or if they are production-related.

