

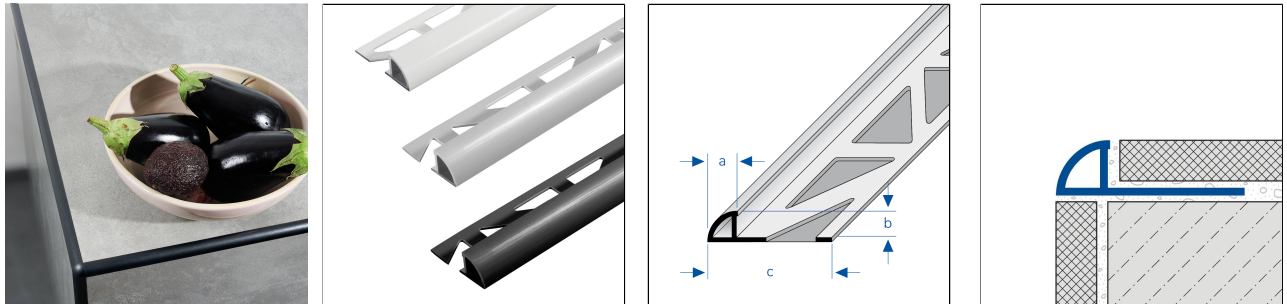

DURONDELL PVC

Round Edge Trim Profile Made Of PVC



ACCESSORIES

Matching corner pieces are available as accessories

MATERIAL

PVC is particularly suitable for indoor and outdoor areas with low mechanical loads. The material is dyed throughout and is therefore UV-resistant under normal circumstances. However, colour differences may occur with constant UV exposure.

The applicability with regard to mechanical and chemical resistance must always be checked on a case-by-case basis.

Note: When using coloured joint mortar with ultra-fine colour pigments in conjunction with plastic profiles, irreversible profile staining may occur. We recommend the use of appropriate protective measures

CARE

PVC does not require any special care. It can be cleaned as needed with just clear, clean water with a few drops of washing-up liquid added.

Solvent-based and abrasive cleaning agents should be avoided.

PROCESSING

1. Select the profile according to the tile thickness.
2. Apply tile adhesive with a notched trowel.
3. Press the profile into the adhesive bed and align.
4. Fill over the entire surface of the fixing leg.
5. Press the tiles firmly into place and align them so that they are flush with the upper edge of the profile. Lay the tiles fully flush.
6. Use suitable inner or outer corner pieces.
7. Leave a grout line of 1-2 mm to the profile.
8. Fill the space between the tiles and the profile completely with grout.

Protect visible surfaces from contact with tile adhesive or grout and, if necessary, clean immediately with a cloth and clean water. Then wipe dry.

Please note: For technical reasons, tolerances in color effects of the materials and print are possible. All information is based on the best of our knowledge and belief. No guarantee can be derived from this. We reserve the right to any technical changes if they are in the interest of progress or if they are production-related.



The generally recognised rules of technology must be observed. Suitability in terms of mechanical and chemical resistance must always be checked on a case-by-case basis.

TECHNICAL DIMENSIONS AND PRODUCT VARIANTS

Material	[PVC]
Colour	silver grey, black, white
Length	250 cm, 300 cm
sight width	7.5 mm, 9.5 mm, 11.5 mm, 12.5 mm, 14 mm
Height	12.5 mm, 6 mm, 8 mm, 10 mm, 11 mm

PRODUCT VARIANTS

Ident	Height	Colour	Length
DRP 633/250	6 mm	black	250 cm
DRP 651/250	6 mm	silver grey	250 cm
DRP 630/250	6 mm	white	250 cm
DRP 833/250	8 mm	black	250 cm
DRP 851/250	8 mm	silver grey	250 cm
DRP 830/250	8 mm	white	250 cm
DRP 830/300	8 mm	white	300 cm
DRP 1033/250	10 mm	black	250 cm
DRP 1051/250	10 mm	silver grey	250 cm
DRP 1030/250	10 mm	white	250 cm
DRP 1030/300	10 mm	white	300 cm
DRP 1133/250	11 mm	black	250 cm
DRP 1151/250	11 mm	silver grey	250 cm
DRP 1130/250	11 mm	white	250 cm
DRP 1233/250	12.5 mm	black	250 cm
DRP 1251/250	12.5 mm	silver grey	250 cm
DRP 1230/250	12.5 mm	white	250 cm
DRP 1230/300	12.5 mm	white	300 cm

Please note: For technical reasons, tolerances in color effects of the materials and print are possible. All information is based on the best of our knowledge and belief. No guarantee can be derived from this. We reserve the right to any technical changes if they are in the interest of progress or if they are production-related.