

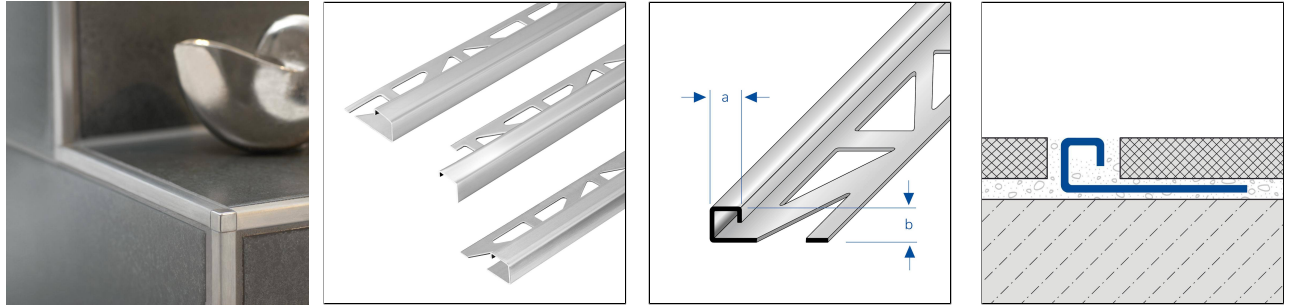

SQUARELINE Stainless Steel (304)

Square Box Trim Profile Made Of Stainless Steel



TECHNICAL DIMENSIONS AND PRODUCT VARIANTS

Material	Stainless Steel (304)
Surface	natural, high-gloss polished, gebürstet
Colour	natural, silver
Length	250 cm, 300 cm
sight width	13.5 mm, 8 mm, 10 mm, 11 mm, 12 mm
Height (b)	12.5 mm, 7 mm, 9 mm, 10 mm, 11 mm

ACCESSORIES

Matching corner pieces are available as accessories.

MATERIAL

Stainless steel (V2A/304) is particularly suitable for areas of application subject to high mechanical stresses and where particularly high demands are placed on cleanliness, hygiene and chemical resistance. Contact with products containing hydrochloric acid should be avoided.

Tools made of unalloyed steel must not be used during processing. Open cut edges are not rust-resistant. If necessary, separate rust protection must be applied to cut-edges.

Depending on the environmental conditions, rust film may also form on stainless steel and should be removed immediately.

The usability in terms of mechanical and chemical resistance must always be checked on a case-by-case basis.

CARE

Stainless steel (V2A/304) does not require any special care. If necessary, it can simply be cleaned with clear, clean water and a few drops of washing-up liquid. Then wipe dry.

Acidic, alkaline and abrasive cleaning agents should be avoided. Flash rust can be removed with commercially available polishes suitable for stainless steel.

PROCESSING

1. Select the profile according to the tile thickness.

25 April 2025 06:12 PM

Please note: For technical reasons, tolerances in color effects of the materials and print are possible. All information is based on the best of our knowledge and belief. No guarantee can be derived from this. We reserve the right to any technical changes if they are in the interest of progress or if they are production-related.



2. Apply tile adhesive with a notched trowel.
3. Press the profile into the adhesive bed and align.
4. Fill over the entire surface of the fixing leg.
5. Press the tiles firmly into place and align them so that they are flush with the upper edge of the profile. Lay the tiles fully flush.
6. Use suitable inner or outer corner pieces.
7. Leave a joint of 1-2 mm to the profile.
8. Fill the space between the tiles and the profile completely with grout.

Use a slow-running angle grinder with a suitable cutting disc to cut the profiles.

Protect visible surfaces from contact with tile adhesive or grout and, if necessary, clean immediately with a cloth and clean water. Then rub dry.

The generally recognised rules of technology must be observed. Suitability in terms of mechanical and chemical resistance must always be checked on a case-by-case basis.

PRODUCT VARIANTS

Ident	Height (b)	Surface	Colour	Length
DPSE 70-SF/250	7 mm	gebürstet		250 cm
DPSE 70-SP/250	7 mm	high-gloss polished		250 cm
DPSE 70/250	7 mm	natural		250 cm
DPSE 90-SF/250	9 mm	gebürstet	silver	250 cm
DPSE 90-SF/300	9 mm	gebürstet		300 cm
DPSE 90-SP/250	9 mm	high-gloss polished		250 cm
DPSE 90-SP/300	9 mm	high-gloss polished		300 cm
DPSE 90/250	9 mm	natural	natural	250 cm
DPSE 90/300	9 mm	natural		300 cm
DPSE 100-SF/250	10 mm	gebürstet		250 cm
DPSE 100-SF/300	10 mm	gebürstet		300 cm
DPSE 100-SP/250	10 mm	high-gloss polished		250 cm
DPSE 100-SP/300	10 mm	high-gloss polished		300 cm
DPSE 100/250	10 mm	natural		250 cm
DPSE 100/300	10 mm	natural		300 cm
DPSE 110-SF/250	11 mm	gebürstet	silver	250 cm
DPSE 110-SF/300	11 mm	gebürstet		300 cm
DPSE 110-SP/250	11 mm	high-gloss polished		250 cm
DPSE 110-SP/300	11 mm	high-gloss polished		300 cm
DPSE 110/250	11 mm	natural	natural	250 cm
DPSE 110/300	11 mm	natural		300 cm
DPSE 125-SF/250	12.5 mm	gebürstet	silver	250 cm
DPSE 125-SF/300	12.5 mm	gebürstet		300 cm
DPSE 125-SP/250	12.5 mm	high-gloss polished		250 cm

25 April 2025 06:12 PM

Please note: For technical reasons, tolerances in color effects of the materials and print are possible. All information is based on the best of our knowledge and belief. No guarantee can be derived from this. We reserve the right to any technical changes if they are in the interest of progress or if they are production-related.



DPSE 125-SP/300	12.5 mm	high-gloss polished		300 cm
DPSE 125/250	12.5 mm	natural	natural	250 cm
DPSE 125/300	12.5 mm	natural		300 cm

25 April 2025 06:12 PM

Please note: For technical reasons, tolerances in color effects of the materials and print are possible.
All information is based on the best of our knowledge and belief. No guarantee can be derived from this.
We reserve the right to any technical changes if they are in the interest of progress or if they are production-related.

DURAL GmbH | Südring 11 | D-56412 Ruppach-Goldhausen | Germany | +49 2602/9261-0 | info@dural.com

The recognised standards and regulations of technology must be observed. Previous data sheets are invalid.

www.dural.com

