

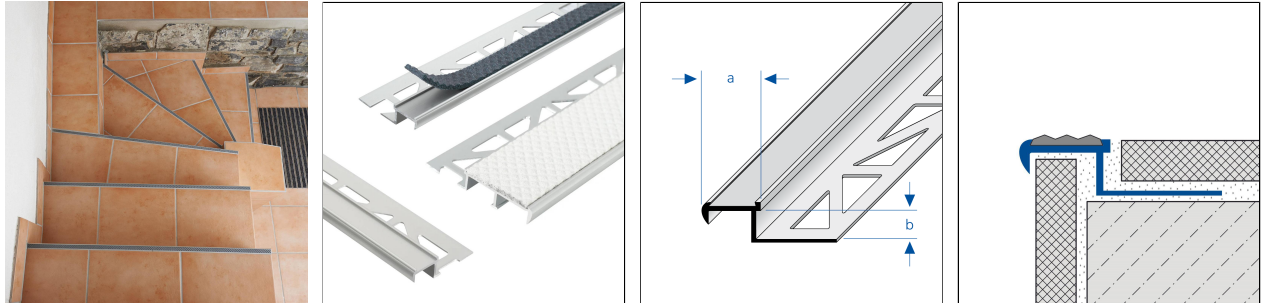

DIAMONDSTEP

Stair nosing profile with and without anti-slip safety insert for tiled stairs.



TECHNICAL DIMENSIONS AND PRODUCT VARIANTS

Material	[Aluminium], [Aluminium],[PVC], [Stainless Steel (304)], [Stainless Steel (304)],[PVC]
Surface	[anodised], [natural]
Colour	silver, neutral black, charcoal grey, rich brown, putty, mid grey, natural
Length	150 cm, 250 cm
sight width	17 mm, 25 mm, 42 mm
Height	9 mm, 11 mm
Width mm	17 mm, 25 mm, 42 mm
Supplementary colour	Profilfarbe: natur, neutral black, charcoal grey, rich brown, putty, mid grey

PRODUCT VARIANTS

Ident	Height	Surface	Colour	Length
DISTAE 90/250	9 mm	anodised	silver	250 cm
DISTAE 90-42/250	9 mm	anodised	silver	250 cm
DISTAE 9106/250	9 mm	anodised	silver	250 cm
DISTAE 9107/250	9 mm	anodised	silver	250 cm
DISTAE 9109/250	9 mm	anodised	silver	250 cm
DISTAE 9110/250	9 mm	anodised	silver	250 cm
DISTAE 9113/250	9 mm	anodised	silver	250 cm
DISTAE 11107/150	11 mm	anodised	charcoal grey	150 cm
DISTAE 11113/150	11 mm	anodised	mid grey	150 cm
DISTAE 11106/150	11 mm	anodised	neutral black	150 cm
DISTAE 11110/150	11 mm	anodised	putty	150 cm
DISTAE 11109/150	11 mm	anodised	rich brown	150 cm
DISTAE 110/250	11 mm	anodised	silver	250 cm
DISTAE 110-42/250	11 mm	anodised	silver	250 cm
DISTAE 11106/250	11 mm	anodised	silver	250 cm
DISTAE 11107/250	11 mm	anodised	silver	250 cm

Please note: For technical reasons, tolerances in color effects of the materials and print are possible. All information is based on the best of our knowledge and belief. No guarantee can be derived from this. We reserve the right to any technical changes if they are in the interest of progress or if they are production-related.



DISTAE 11109/250	11 mm	anodised	silver	250 cm
DISTAE 11110/250	11 mm	anodised	silver	250 cm
DISTAE 11113/250	11 mm	anodised	silver	250 cm
DISTE 110/250	11 mm	natural	natural	250 cm
DISTE 11106/250	11 mm	natural	natural	250 cm
DISTE 11107/250	11 mm	natural	natural	250 cm
DISTE 11109/250	11 mm	natural	natural	250 cm
DISTE 11110/250	11 mm	natural	natural	250 cm
DISTE 11113/250	11 mm	natural	natural	250 cm

[Data sheet Accessories](#)

Insert Slip resistance class R10 / V6

Matching end caps are available as accessories.

PROPERTIES

Insert Slip resistance class R10 / V6

MATERIAL

Aluminium can be used wherever medium mechanical stress is to be expected. Contact with alkaline materials (e.g. tile adhesive) can cause discolouration that is almost impossible to remove. High humidity during the drying phase can intensify this process. Always wipe tile adhesive or grout off visible surfaces immediately with plenty of water, then wipe dry and ensure good room ventilation.

Stainless steel V2A/304 is particularly suitable for applications subject to high mechanical stress and for particularly high requirements in terms of cleanliness, hygiene and chemical resistance. Contact with products containing hydrochloric acid must be avoided. Tools made of unalloyed steel must not be used during processing. Open cut edges are not rust-resistant. If necessary, separate rust protection must be applied. Even with stainless steel, flash rust is possible depending on the environmental conditions and should be removed immediately.

The suitability with regard to mechanical and chemical resistance must always be checked in each individual case.

PROCESSING

1. Select the profile according to the tile thickness.
2. Apply tile adhesive with a notched trowel.
3. Press the profile into the adhesive bed and align it.
4. Fill the fixing flange completely with adhesive.
5. Press the tiles firmly into place and align them so that they are flush with the top edge of the profile. Lay the tiles so that they are completely covered.
6. Cut the profile to mitre for corner formation. Seal the mitre joint with a neutral cross-linked silicon.
7. Leave a 1-2 mm joint between the profile and the tiles.
8. Fill the space between the tiles and the profile completely with joint mortar.

Protect visible surfaces from contact with tile adhesive or grout and clean immediately with a cloth and clear water if necessary. Then rub dry.

To cut stainless steel, use a slow-running angle grinder with a suitable cutting disc. Prevent cutting sparks from settling on the profile surfaces.

Please note: For technical reasons, tolerances in color effects of the materials and print are possible. All information is based on the best of our knowledge and belief. No guarantee can be derived from this. We reserve the right to any technical changes if they are in the interest of progress or if they are production-related.





The generally accepted rules of technology and tiling must be observed. Suitability for use with mechanical and chemical resistance must always be checked in each individual case.

CARE

Aluminium does not require any special care. If necessary, it can be cleaned with clear, clean water and a few drops of washing-up liquid. Then wipe dry.

Stainless steel (304) does not require any special care. If necessary, it can be cleaned with clear, clean water and a few drops of washing-up liquid. Then wipe dry. Flash rust can be removed with commercially available polishes suitable for stainless steel.

Avoid using acidic, alkaline and abrasive cleaning agents.

Please note: For technical reasons, tolerances in color effects of the materials and print are possible.
All information is based on the best of our knowledge and belief. No guarantee can be derived from this.
We reserve the right to any technical changes if they are in the interest of progress or if they are production-related.