

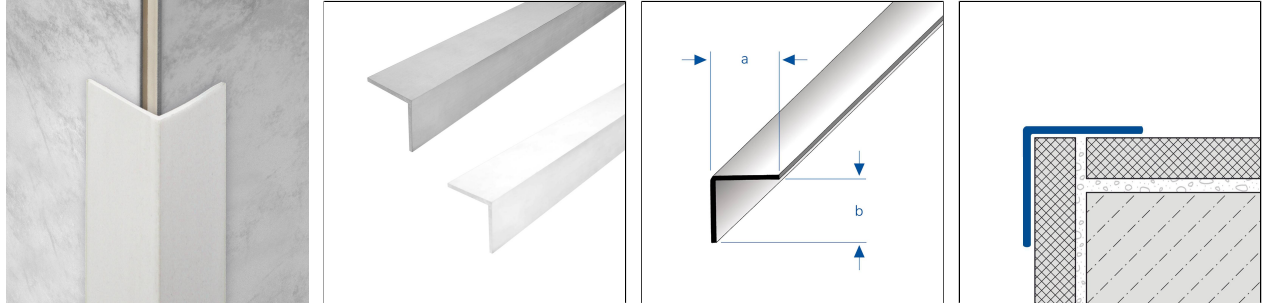

DURAGARD WP

Corner protection profile for retrofitting



TECHNICAL DIMENSIONS AND PRODUCT VARIANTS

Material	[Aluminium], [PVC]
Surface	[natural]
Colour	natural, white, grey
Length	250 cm, 300 cm
sight width	20 mm, 25 mm, 30 mm, 40 mm
Height	20 mm, 25 mm, 30 mm, 40 mm
Width mm	20 mm, 25 mm, 30 mm, 40 mm
Strength mm	2 mm, 3 mm, 1,5 mm
dimension	20 x 20, 25 x 25, 30 x 30, 40 x 40

PRODUCT VARIANTS

Ident	Height	Surface	Colour	Length
WPA 2020/300	20 mm	natural	natural	300 cm
WPP 38/2020/250	20 mm		grey	250 cm
WPP 30/2020/250	20 mm		white	250 cm
WPA 2525/300	25 mm	natural	natural	300 cm
WPP 38/2525/250	25 mm		grey	250 cm
WPP 30/2525/250	25 mm		white	250 cm
WPA 3030/300	30 mm	natural	natural	300 cm
WPP 30/3030/250	30 mm		white	250 cm
WPA 4040/300	40 mm	natural	natural	300 cm

MATERIAL

Aluminium can be used wherever a medium mechanical stresses are expected. Contact with alkaline materials (e.g. tile adhesive) can lead to discolouration, which can be difficult to remove afterwards. High humidity during the drying phase can intensify this process. Always wipe off tile adhesive or grout on visible surfaces immediately with plenty of water, then wipe dry and ensure that the room is well ventilated.

Please note: For technical reasons, tolerances in color effects of the materials and print are possible. All information is based on the best of our knowledge and belief. No guarantee can be derived from this. We reserve the right to any technical changes if they are in the interest of progress or if they are production-related.



Suitability in terms of mechanical and chemical resistance must always be checked on a case-by-case basis.

PROCESSING

1. The bonding surfaces must be cleaned and any contamination such as release agents, preservatives, grease, oil, dust, water, old adhesives/sealants and other substances that could impair adhesion must be removed.
2. Apply SPEED-FLEX adhesive sealant or a suitable alternative to the adhesive sides of the profile. In terms of installation, the internal or external corner pieces should be attached first, then the profile should be inserted in without a joint.
3. Place the profile flush in the corner and press firmly.
4. Mitre the profile to form the corner. Seal the mitre joint with a neutral-curing silicone.
5. Close the open ends with the appropriate end caps.
6. Allow any adhesive sealant that has escaped to dry, then carefully cut along the profile edge with a sharp knife without damaging the substrate and then remove.

Note: The profile does not replace sealing/waterproofing. If necessary, this must be carried out separately using suitable measures.

The generally recognised rules of technology must be observed. The suitability with regard to mechanical and chemical resistance must always be checked in each individual case.

CARE

Aluminium does not require any special care. If necessary, it can simply be damp-cleaned with clear, clean water and a few drops of washing-up liquid. Then wipe dry.

Acidic, alkaline and abrasive cleaning agents should be avoided.

Please note: For technical reasons, tolerances in color effects of the materials and print are possible.
All information is based on the best of our knowledge and belief. No guarantee can be derived from this.
We reserve the right to any technical changes if they are in the interest of progress or if they are production-related.