

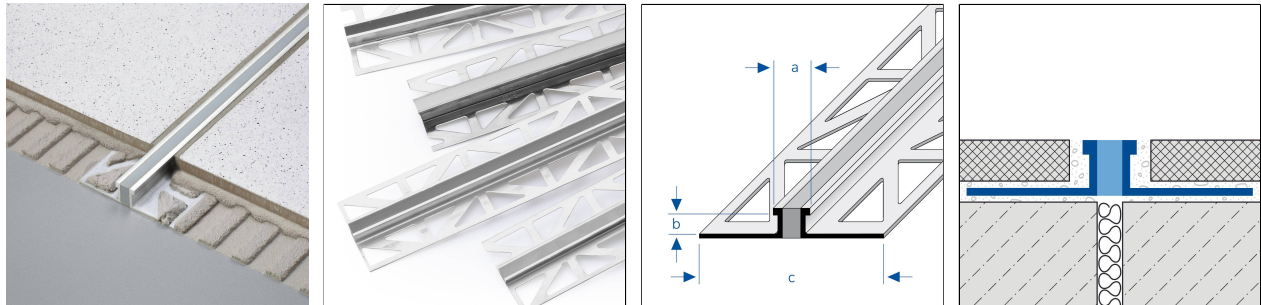

# DURAFLEX METAL Aluminium

## Expansion and movement joint profile for thin-bed installation



### TECHNICAL DIMENSIONS AND PRODUCT VARIANTS

Material	[Aluminium]
Surface	[natural]
Colour	natural
Length	250 cm
sight width	10 mm
Height	12.5 mm, 16.5 mm, 3 mm, 6 mm, 8 mm, 10 mm, 4.5 mm, 15 mm, 18 mm, 20 mm, 22 mm, 25 mm, 30 mm
Supplementary colour	EPDM insert: grey

### PRODUCT VARIANTS

Ident	Height	Surface	Colour	Length
DFA 338/250	3 mm	natural	natural	250 cm
DFA 438/250	4.5 mm	natural	natural	250 cm
DFA 638/250	6 mm	natural	natural	250 cm
DFA 838/250	8 mm	natural	natural	250 cm
DFA 1038/250	10 mm	natural	natural	250 cm
DFA 1238/250	12.5 mm	natural	natural	250 cm
DFA 1538/250	15 mm	natural	natural	250 cm
DFA 1638/250	16.5 mm	natural	natural	250 cm
DFA 1838/250	18 mm	natural	natural	250 cm
DFA 2038/250	20 mm	natural	natural	250 cm
DFA 2238/250	22 mm	natural	natural	250 cm
DFA 2538/250	25 mm	natural	natural	250 cm
DFA 3038/250	30 mm	natural	natural	250 cm

### MATERIAL

Please note: For technical reasons, tolerances in color effects of the materials and print are possible. All information is based on the best of our knowledge and belief. No guarantee can be derived from this. We reserve the right to any technical changes if they are in the interest of progress or if they are production-related.



Aluminum/EPDM can be used wherever a medium mechanical load-bearing capacity is to be expected. Contact with alkaline materials (e.g. tile adhesive) can lead to discoloration, which can be difficult to remove afterwards. High humidity during the drying phase can intensify this process. Always wipe off tile adhesive or grout on visible surfaces immediately with plenty of water, then wipe dry and ensure that the room is well ventilated.

Suitability in terms of mechanical and chemical resistance must always be checked on a case-by-case basis.

## PROCESSING

1. select the profile according to the tile thickness.
- 2 Apply tile adhesive with a notched trowel.
3. press the profile into the adhesive bed and align. Expansion joints from the substrate must be taken over congruently.
4. fill over the entire surface of the fixing leg.
5. press the tiles firmly into place and align them so that they are flush with the top edge of the profile. Lay the tiles fully.
6. leave a joint of 1-2 mm to the profile.
7. fill the space between the tiles and the profile completely with grout.

Protect visible surfaces from contact with tile adhesive or grout and, if necessary, clean immediately with a cloth and clean water. Then rub dry.

The generally recognized rules of technology must be observed. Suitability in terms of mechanical and chemical resistance must always be checked on a case-by-case basis.

## CARE

Aluminum/EPDM does not require any special care. If necessary, it can simply be damp-cleaned with clear, clean water and a few drops of washing-up liquid. Then wipe dry.

Acidic and abrasive cleaning agents should be avoided.

Please note: For technical reasons, tolerances in color effects of the materials and print are possible.  
All information is based on the best of our knowledge and belief. No guarantee can be derived from this.  
We reserve the right to any technical changes if they are in the interest of progress or if they are production-related.