

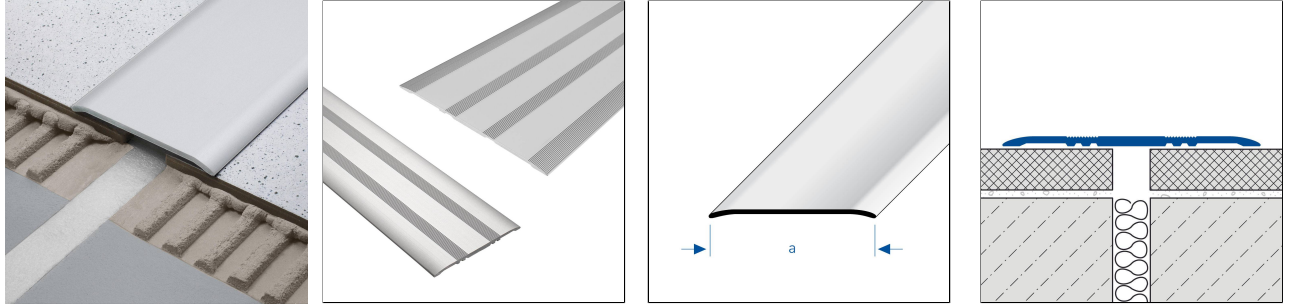

DURAFLEX KA without hole



TECHNICAL DIMENSIONS AND PRODUCT VARIANTS

Material	Aluminium
Surface	natural, anodised
Colour	natural, silver
Length	250 cm
Höhe (b)	3.5 mm, 4 mm

PRODUCT VARIANTS

Ident	Höhe (b)	Surface	Colour	Length
DFAE KA 600/250	3.5 mm	anodised	silver	250 cm
DFAE KA 800/250	3.5 mm	anodised	silver	250 cm
DFA KA 600/250	3.5 mm	natural	natural	250 cm
DFA KA 800/250	3.5 mm	natural	natural	250 cm
DFAE KA 1000/250	4 mm	anodised	silver	250 cm
DFAE KA 1200/250	4 mm	anodised	silver	250 cm
DFA KA 1000/250	4 mm	natural	natural	250 cm
DFA KA 1200/250	4 mm	natural	natural	250 cm

02 January 2025 04:39 PM

Please note: For technical reasons, tolerances in color effects of the materials and print are possible. All information is based on the best of our knowledge and belief. No guarantee can be derived from this. We reserve the right to any technical changes if they are in the interest of progress or if they are production-related.

