

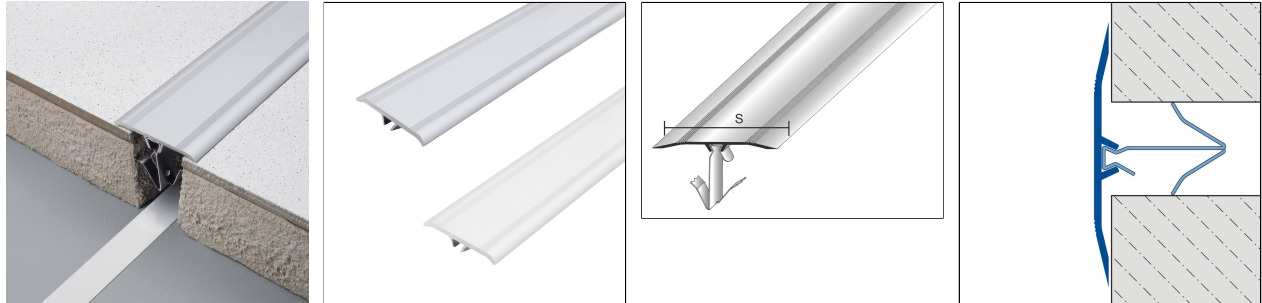

DURAFLEX KF

Cover profile for expansion and movement joints in walls and floors without retaining clips.



TECHNICAL DIMENSIONS AND PRODUCT VARIANTS

Material	[Aluminium]
Surface	[anodised]
Colour	silver
Length	300 cm
Width mm	50 mm, 60 mm, 70 mm, 90 mm, 140 mm

PRODUCT VARIANTS

Ident	Surface	Colour	Length
DFAE KF 140/300	anodised	silver	300 cm
DFAE KF 50/300	anodised	silver	300 cm
DFAE KF 60/300	anodised	silver	300 cm
DFAE KF 70/300	anodised	silver	300 cm
DFAE KF 90/300	anodised	silver	300 cm

Data sheet Accessories

PVC profiles only for floors in 50 and 70 mm widths
 Corner design only in aluminium in 50, 60, 70 and 90 mm widths

Stainless steel retaining clips (V4A/304) A or B (depending on joint width)

Requirements for floor application: approx. 11 clips/profile

Requirements for wall application: approx. 6 clips/profile

PROPERTIES

PVC profiles only for floors in 50 and 70 mm widths
 Corner design only in aluminium in 50, 60, 70 and 90 mm widths

MATERIAL

Aluminium can be used wherever moderate mechanical stress is expected. Contact with alkaline materials (e.g. tile adhesive) can lead to discolouration that is difficult to remove afterwards. High humidity during the drying phase can intensify this process. Always wipe tile adhesive or grout off visible surfaces immediately with plenty of water, then wipe dry and ensure good room ventilation.

Please note: For technical reasons, tolerances in color effects of the materials and print are possible. All information is based on the best of our knowledge and belief. No guarantee can be derived from this. We reserve the right to any technical changes if they are in the interest of progress or if they are production-related.



PVC is particularly suitable for indoor and outdoor areas with low mechanical stress. The material is dyed throughout and therefore UV-resistant under normal circumstances, but colour differences may occur with constant UV exposure.

Note: When using coloured grout with ultra-fine colour pigments in combination with plastic profiles, irreversible profile staining may occur. We recommend the use of appropriate protective measures.

Suitability in terms of mechanical and chemical resistance must always be checked on a case-by-case basis.

PROCESSING

1. Select the profile according to the joint width and application (wall or floor).

Floor application

Joint width 15–20 mm = profile width 50 mm (retaining clip type A)

Joint width 20–30 mm = profile width 60 mm (retaining clip type A)

Joint width 25–35 mm = profile width 70 mm (retaining clip type B)

Joint width 30–45 mm = profile width 90 mm (retaining clip type B)

Wall application:

Joint width 15–30 mm = profile width 50 mm (retaining clip type A)

Joint width 20–45 mm = profile width 60 mm (retaining clip type B)

Joint width 30–45 mm = profile width 70 mm (retaining clip type B)

Joint width 35–45 mm = profile width 90 mm (retaining clip type B)

Joint width 40–45 mm = profile width 140 mm (retaining clip type B)

2. Select the appropriate clip depending on the joint width.

3. Insert the clips into the guide rail on the back of the profile (every 30 cm for floors and 60 cm for walls).

4. Press the profiles and clips into the joints.

The generally accepted rules of technology and tiling must be observed. Suitability for use with mechanical and chemical resistance must always be checked in each individual case.

CARE

Aluminium does not require any special care. If necessary, it can simply be cleaned with clear, clean water and a few drops of washing-up liquid. Then wipe dry.

Avoid using acidic and abrasive cleaning agents.

PVC does not require any special care. If necessary, it can simply be cleaned with clear, clean water and a few drops of washing-up liquid.

Solvent-based and abrasive cleaning agents should be avoided.

Please note: For technical reasons, tolerances in color effects of the materials and print are possible. All information is based on the best of our knowledge and belief. No guarantee can be derived from this. We reserve the right to any technical changes if they are in the interest of progress or if they are production-related.