

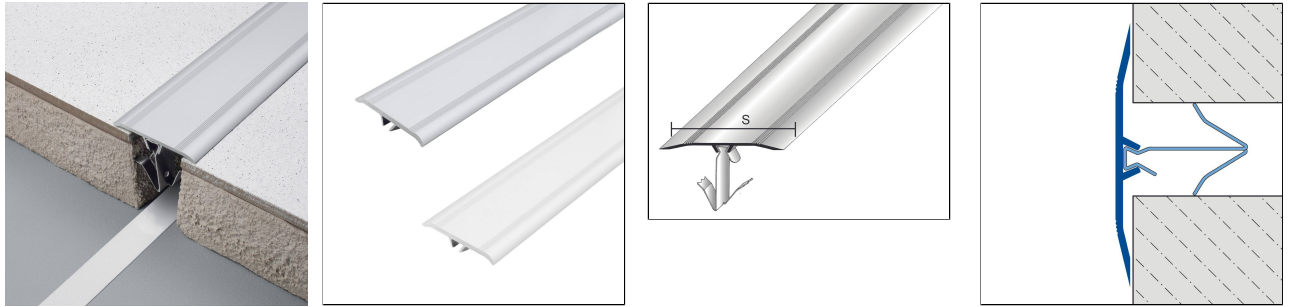

# DURAFLEX KF

Cover Profile Made Of Aluminium Or PVC For Expansion And Movement Joints



## TECHNICAL DIMENSIONS AND PRODUCT VARIANTS

Material	Aluminium, PVC
Surface	anodised
Colour	silver, white, beige, grey
Length	300 cm
Height (b)	15 mm, 21 mm
Width mm	50 mm, 60 mm, 70 mm, 90 mm, 140 mm

## PRODUCT VARIANTS

Ident	Height (b)	Surface	Colour	Length
DFP KF 7032/300	15 mm		beige	300 cm
DFP KF 5030/300	15 mm		white	300 cm
DFP KF 7038/300	21 mm		grey	300 cm
DFP KF 7030/300	21 mm		white	300 cm
DFAE KF 140/300		anodised	silver	300 cm
DFAE KF 50/300		anodised	silver	300 cm
DFAE KF 60/300		anodised	silver	300 cm
DFAE KF 70/300		anodised	silver	300 cm
DFAE KF 90/300		anodised	silver	300 cm

05 February 2025 03:58

Please note: For technical reasons, tolerances in color effects of the materials and print are possible. All information is based on the best of our knowledge and belief. No guarantee can be derived from this. We reserve the right to any technical changes if they are in the interest of progress or if they are production-related.