

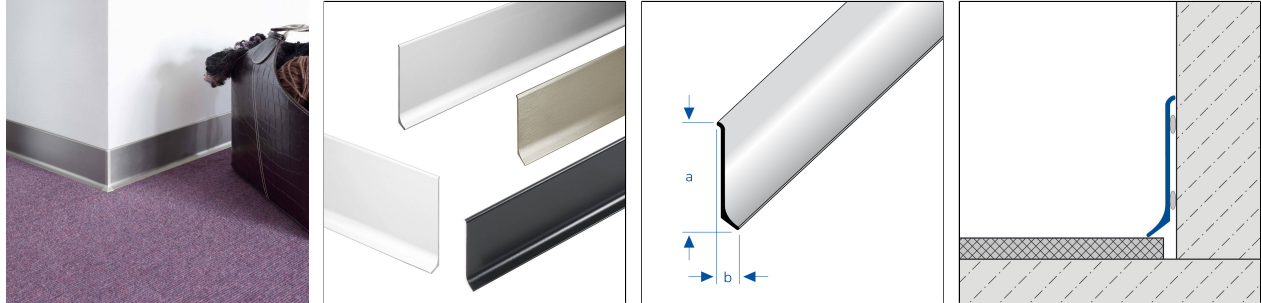

CONSTRUCT Metal

One-piece skirting strip for adhesive mounting



TECHNICAL DIMENSIONS AND PRODUCT VARIANTS

Material	[Aluminium], [Stainless Steel (304)]
Surface	[powder coated], [anodised], [anodised],[brushed], [high-gloss polished]
Colour	silver, champagne, titanium, natural, white (RAL 9003), black matt (RAL 9005)
Length	250 cm
Height	40, 60, 80, 100
Width mm	11 mm

PRODUCT VARIANTS

Ident	Height	Surface	Colour	Length
CAE 40/250	40	anodised	silver	250 cm
CAE 60-C/250	60	anodised	champagne	250 cm
CAE 60/250	60	anodised	silver	250 cm
CAE 60-T/250	60	anodised	titanium	250 cm
CAE 60-C-SF/250	60	anodised, brushed	champagne	250 cm
CAE 60-SF/250	60	anodised, brushed	silver	250 cm
CAE 60-T-SF/250	60	anodised, brushed	titanium	250 cm
CE 60/250	60	high-gloss polished	natural	250 cm
CACM 6011/250	60	powder coated	black matt (RAL 9005)	250 cm
CAC 6030/250	60	powder coated	white (RAL 9003)	250 cm
CAE 80-C/250	80	anodised	champagne	250 cm
CAE 80/250	80	anodised	silver	250 cm
CAE 80-T/250	80	anodised	titanium	250 cm
CAE 80-SF/250	80	anodised, brushed	silver	250 cm
CE 80/250	80	high-gloss polished		250 cm
CACM 8011/250	80	powder coated	black matt (RAL 9005)	250 cm
CAC 8030/250	80	powder coated	white (RAL 9003)	250 cm
CAE 100-C/250	100	anodised	champagne	250 cm
CAE 100/250	100	anodised	silver	250 cm
CAE 100-T/250	100	anodised	titanium	250 cm

Please note: For technical reasons, tolerances in color effects of the materials and print are possible. All information is based on the best of our knowledge and belief. No guarantee can be derived from this. We reserve the right to any technical changes if they are in the interest of progress or if they are production-related.



Data sheet Accessories

Curving in a radius of 100 cm or more possible with the Z-FLEX curver

Matching corner pieces, end caps and connectors are available as accessories

PROPERTIES

Curving in a radius of 100 cm or more possible with the Z-FLEX curver

MATERIAL

Aluminium can be used wherever a medium mechanical stresses are expected. Contact with alkaline materials (e.g. tile adhesive) can lead to discolouration, which can be difficult to remove afterwards. High humidity during the drying phase can intensify this process. Always wipe off tile adhesive or grout on visible surfaces immediately with plenty of water, then wipe dry and ensure that the room is well ventilated.

Suitability in terms of mechanical and chemical resistance must always be checked on a case-by-case basis.

PROCESSING

1. The bonding surfaces must be cleaned and any contamination such as release agents, preservatives, grease, oil, dust, water, old adhesives/sealants and other substances that could impair adhesion must be removed.
2. Apply SPEED-FLEX adhesive sealant or a suitable alternative to the adhesive sides of the profile. In terms of installation, the internal or external corner pieces should be attached first, then the profile should be inserted in without a joint.
3. Place the profile flush in the corner and press firmly.
5. Close the open ends with the appropriate end caps.
6. Allow any adhesive sealant that has escaped to dry, then carefully cut along the profile edge with a sharp knife and then remove.

The generally recognised rules of technology must be observed. The suitability with regard to mechanical and chemical resistance must always be checked in each individual case.

CARE

Aluminium does not require any special care. If necessary, it can simply be damp-cleaned with clear, clean water and a few drops of washing-up liquid. Then wipe dry.

Acidic, alkaline and abrasive cleaning agents should be avoided.

Please note: For technical reasons, tolerances in color effects of the materials and print are possible. All information is based on the best of our knowledge and belief. No guarantee can be derived from this. We reserve the right to any technical changes if they are in the interest of progress or if they are production-related.