

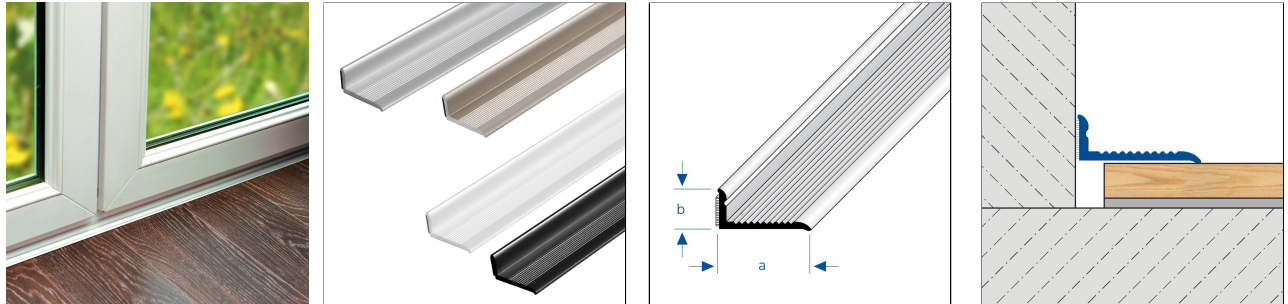

# ADAPT VARIO



## TECHNICAL DIMENSIONS AND PRODUCT VARIANTS

Material	Aluminium
Surface	powder coated, anodised
Colour	silver, titanium, white, black matt (RAL 9005)
Length	270 cm
Sichtbreite (a)	20 mm
Höhe (b)	10 mm

## PRODUCT VARIANTS

Ident	Höhe (b)	Surface	Colour	Length
ADVAE 1800-SK/270	10 mm	anodised	silver	270 cm
ADVAE 1800-T-SK/270	10 mm	anodised	titanium	270 cm
ADVACM 1811-SK/270	10 mm	powder coated	black matt (RAL 9005)	270 cm
ADVAC 1800-SK/270	10 mm	powder coated	white	270 cm

02 January 2025 05:33 PM

Please note: For technical reasons, tolerances in color effects of the materials and print are possible. All information is based on the best of our knowledge and belief. No guarantee can be derived from this. We reserve the right to any technical changes if they are in the interest of progress or if they are production-related.