

Wolf Post Top Bracket

Wolf Post Top Bracket Double Silver Grey
Code: AWOLFB/D/SG/1

Category	Floodlights
Application	Commercial, Industrial, Outdoor, Retail
Specification	Architectural

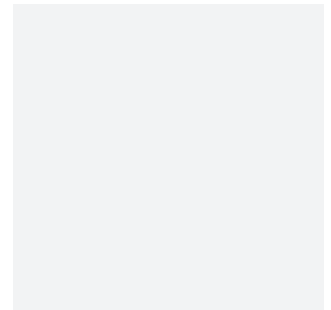
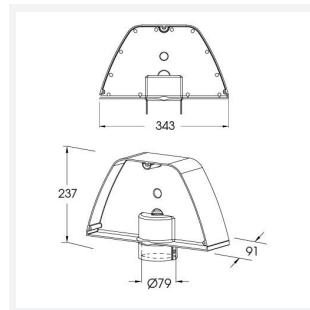
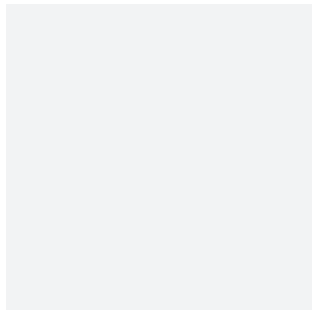

- Accessory for the Wolf wall pack

- Double wall pack post top bracket

GENERAL INFORMATION

Product Weight without Packaging 1.665

TECHNICAL INFORMATION

Colour / Finish	Silver Grey
Internal / External	External
Surface / Recessed / Suspended	Pole
Warranty (Years)	5

