

Wolf Post Top Bracket

Wolf Post Top Bracket Double Black
Code: AWOLFB/D/BLK/1

Category	Floodlights
Application	Commercial, Industrial, Outdoor, Retail
Specification	Architectural

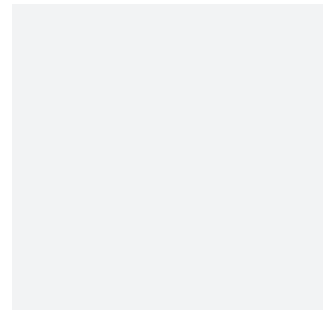
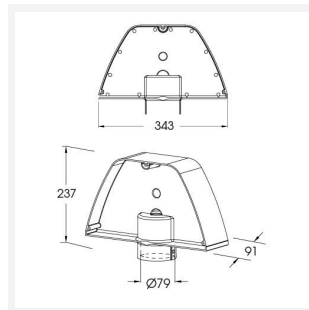
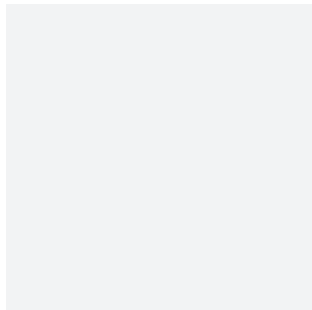

• Accessory for the Wolf wall pack

• Double wall pack post top bracket

TECHNICAL INFORMATION

Colour / Finish	Black
Internal / External	External
Surface / Recessed / Suspended	Pole
Warranty (Years)	5

