

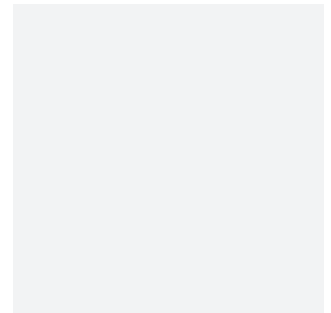

Category	Feature Lighting
Application	Outdoor, Residential
Specification	Performance

# GU10/MR16 Inground Uplight

GU10/MR16 Inground Uplight Stainless Steel  
Code: AWO50

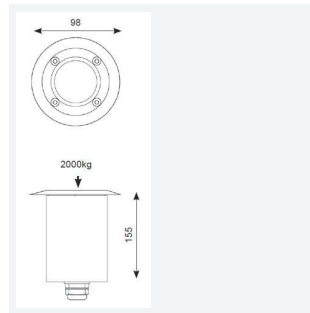

- GU10 inground uplight suitable for residential applications
- Compact inground uplight which accepts 12V and LED lamps
- 316 stainless steel top ring and stainless steel allen key screws
- Supplied with recessed sleeve in high resistant thermoplastic
- Supplied with GU10 lampholder
- Housing in die-cast aluminium with clear toughened glass diffuser of 10mm thickness
- Static load test to 2000kg; suitable for vehicular and pedestrian traffic
- Option to add OCTO Connected by WiZ smart GU10 lamp

## GENERAL INFORMATION

Wattage	50W
Input	230V/12V
Operating Temp	-10°C - 25°C
Cut-Out Size	94mm with sleeve, 80mm without sleeve
Product Weight without Packaging	1.021 kg

## TECHNICAL INFORMATION

Light Source	GU10 / MR16
Colour / Finish	Stainless Steel
IP Rating	IP67
Class Protection	1 & 3
Internal / External	External
Surface / Recessed / Suspended	Recessed
Warranty (Years)	3
CE Mark	Yes
Diameter	98 mm

