

Vision HP

Vision HP Electronic Photocell Graphite

Code: AVILED/HP/GR/PC

Category	Bulkheads
Application	Ancillary, Hospitality, Outdoor, Residential, Retail
Specification	Performance

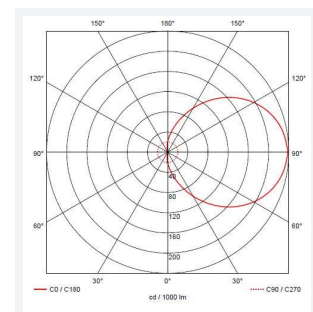
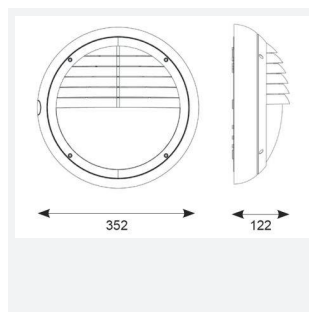
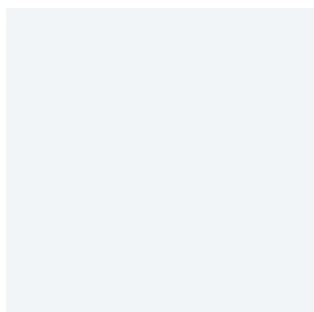
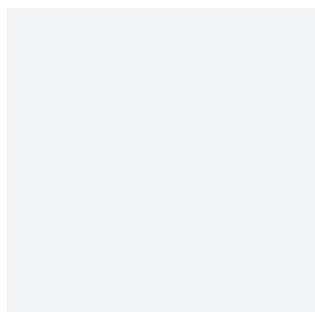

PRODUCT FEATURES

- High powered IP65 polycarbonate LED luminaire suitable for external hospitality and retail applications and ancillary areas
- Integral die-cast aluminium heatsink provides thermally managed high performance
- Powered by Tridonic
- Four conduit entry points
- Dimmable, Photocell, MWS and Emergency options available

GENERAL INFORMATION

Wattage	31W
Lumens Delivered	2400lm
Lm/W	78lm/W
Beam Angle	110
CRI	80
CCT	4000K
Input	220-240V
Operating Temp	-10°C - 50°C
SDCM	6
Product Weight without Packaging	1.852 kg

TECHNICAL INFORMATION

Light Source	LED
Colour / Finish	Graphite
IP Rating	IP65
Class Protection	2
Internal / External	Internal / External
Surface / Recessed / Suspended	Ceiling, Wall
Lumen Depreciation	L70 36,000h
CE Mark	Yes
Diameter	350 mm

