



|                      |   |
|----------------------|---|
| <b>Category</b>      | Emergency   |
| <b>Application</b>   | Ancillary, Commercial, Education, Healthcare, Hospitality, Industrial, Retail |
| <b>Specification</b> | Performance   |

# Twin Spot

Twin Spot Non-Maintained Lithium  
**Code:** ATWS/1/NM

- Twin LED emergency floodlighting for industrial applications
- Robust metal enclosure in an opal colour
- LiFePO4 Lithium battery provides enhanced product lifetime
- Moulded polycarbonate heads

| GENERAL INFORMATION              |            |
|----------------------------------|------------|
| Wattage                          | 2W         |
| Lumens Delivered                 | 440lm      |
| CRI                              | 70         |
| CCT                              | 6500K      |
| Input                            | 220-240V   |
| Operating Temp                   | 0°C - 40°C |
| SDCM                             | 6          |
| Product Weight without Packaging | 1.814 kg   |

| TECHNICAL INFORMATION          |             |
|--------------------------------|-------------|
| Light Source                   | LED         |
| Colour / Finish                | White       |
| IP Rating                      | IP20        |
| Class Protection               | 1           |
| Internal / External            | Internal    |
| Surface / Recessed / Suspended | Wall        |
| Lumen Depreciation             | L70 60,000h |
| Warranty (Years)               | 5           |
| CE Mark                        | Yes         |
| Height                         | 107 mm      |



|                      |   |
|----------------------|---|
| <b>Category</b>      | Emergency   |
| <b>Application</b>   | Ancillary, Commercial, Education, Healthcare, Hospitality, Industrial, Retail |
| <b>Specification</b> | Performance   |

# Twin Spot

Twin Spot Non-Maintained Lithium  
**Code:** ATWS/1/NM

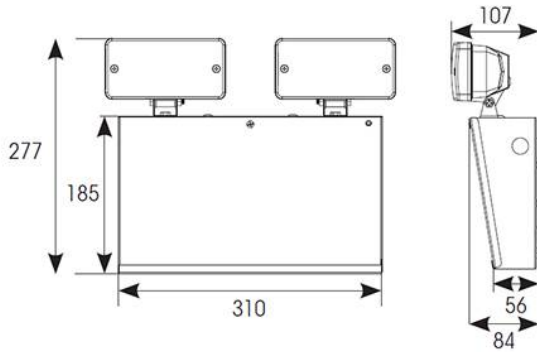

## ACCESSORIES

ASBP/7/LI

Battery Replacement for ATWS/1/NM