



Category	Emergency
Application	Ancillary, Commercial, Education, Healthcare, Hospitality, Industrial, Retail
Specification	Performance

Owl High Output

Owl Twin Spot High Output IP66 Non-Maintained

Code: ATSLED/3NM/ST/HO



PRODUCT FEATURES

- Self-test Twin LED emergency floodlight for industrial applications
- Moulded polycarbonate heads
- Robust white moulded enclosure
- Self-test as standard

GENERAL INFORMATION

Wattage	3W
Lumens Delivered	706lm (Emergency)
Beam Angle	60
CRI	70
CCT	6500K
Input	220-240V
Operating Temp	0°C - 40°C
Product Weight without Packaging	1.602 kg

TECHNICAL INFORMATION

Light Source	LED
Colour / Finish	White
IP Rating	IP66
Class Protection	1
Internal / External	Internal / External
Surface / Recessed / Suspended	Wall
Lumen Depreciation	L70 50,000h
Warranty (Years)	5
CE Mark	Yes
Height	290 mm
Emergency Output Duration	3 Hr



Category	Emergency
Application	Ancillary, Commercial, Education, Healthcare, Hospitality, Industrial, Retail
Specification	Performance

Owl High Output

Owl Twin Spot High Output IP66 Non-Maintained
Code: ATSLED/3NM/ST/HO

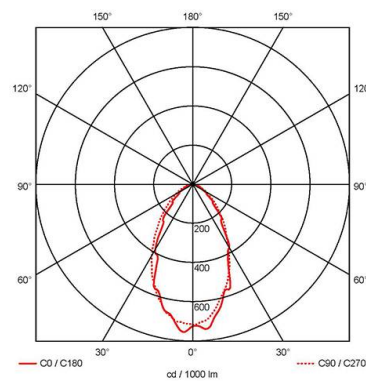
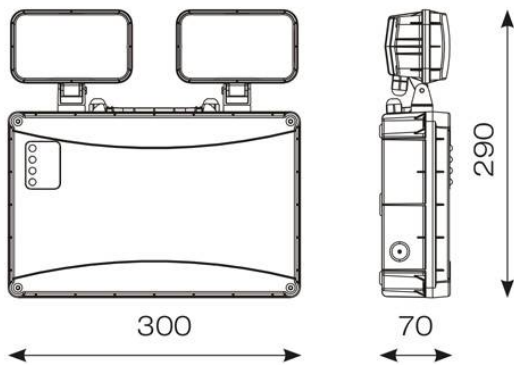

SPARES

ASBP/6/LI

6.4V 5.5Ah-5 Li-FePO4 Replacement Battery

