

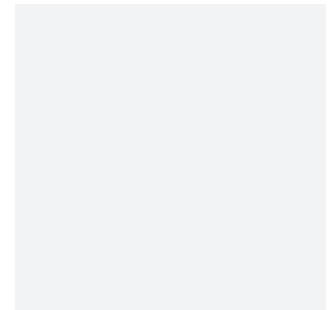

Twistlock GU10 IP44 Gimbal

Twistlock GU10 IP44 Outdoor Die-Cast Gimbal
Code: ATLVOG/IP44/B

Category	Downlights
Application	Hospitality, Residential, Retail
Specification	Architectural

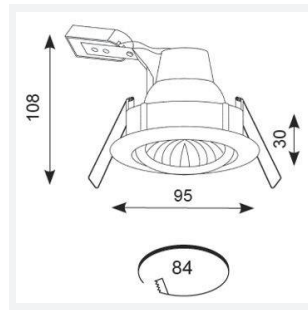
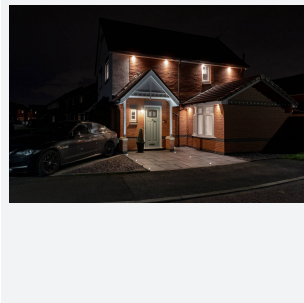
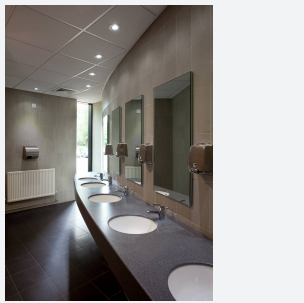

PRODUCT FEATURES

- IP44 rated for exterior applications including soffits (product supplied less lamp)
- DuPont paint finish with 20 year guarantee
- Generous size of terminal housing and 2x1.5mm + CPC loop-in, loop-out push fit terminals provide an easy and efficient installation
- Option to add Bluetooth and WiFi enabled smart WIZ GU10 lamp
- Suitable for GU10 LED only

GENERAL INFORMATION	
Wattage	35W
Input	220/240V
Operating Temp	0°C - 25°C
Cut-Out Size	84
Product Weight without Packaging	0.184 kg

TECHNICAL INFORMATION	
Light Source	GU10
Colour / Finish	Black
IP Rating	IP44
Class Protection	1
Internal / External	Internal / External
Surface / Recessed / Suspended	Recessed
Warranty (Years)	5
CE Mark	Yes
Diameter	93.5 mm
Height	98 mm

