

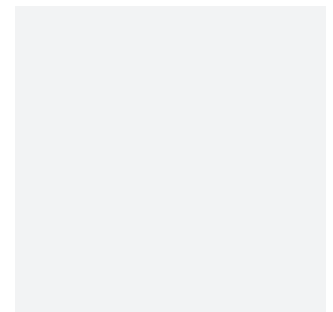

Twistlock GU10 Gimbal

Twistlock GU10 Die-Cast Gimbal Brass
Code: ATLG/BR

| | |
|---------------|----------------------------------|
| Category | Downlights |
| Application | Hospitality, Residential, Retail |
| Specification | Architectural |

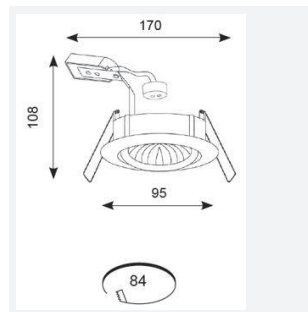
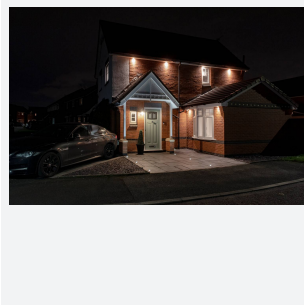
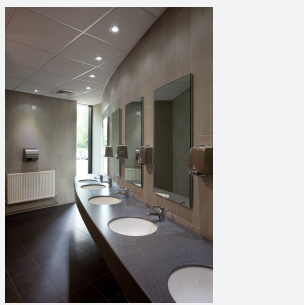

PRODUCT FEATURES

- GU10 die-cast gimbal suitable for residential and hospitality applications (product supplied less lamp)
- Permanent earth on stirrup bracket for GU10 mains earthing
- 30 degree tilt angle
- Manufactured from high grade die-cast aluminium
- Generous size of terminal housing and 2x1.5mm, + CPC loop-in, loop-out push fit terminals provide an easy and efficient installation
- Option to add Bluetooth and WiFi enabled smart WIZ GU10 lamp

| GENERAL INFORMATION | |
|----------------------------------|------------|
| Wattage | 35W |
| Input | 220-240V |
| Operating Temp | 0°C - 25°C |
| Cut-Out Size | 84 |
| Product Weight without Packaging | 0.144 kg |

| TECHNICAL INFORMATION | |
|--------------------------------|----------|
| Light Source | GU10 |
| Colour / Finish | Brass |
| IP Rating | IP20 |
| Class Protection | 1 |
| Internal / External | Internal |
| Surface / Recessed / Suspended | Recessed |
| Warranty (Years) | 5 |
| CE Mark | Yes |
| Diameter | 93.5 mm |
| Height | 108 mm |
| Accessories | ATL/BA |

