

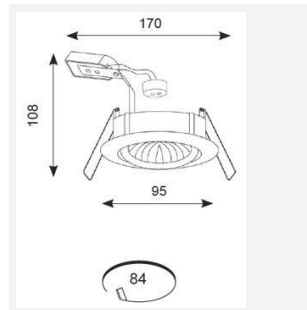

Twistlock GU10 Gimbal

Twistlock GU10 Die-Cast Gimbal Black Chrome
Code: ATLG/BLC

Category	Downlights
Application	Hospitality, Residential, Retail
Specification	Architectural

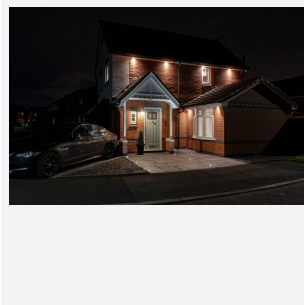
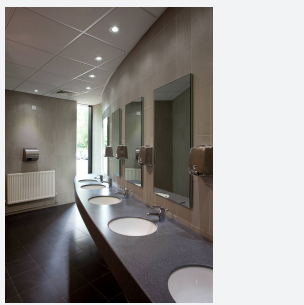

PRODUCT FEATURES

- GU10 die-cast gimbal suitable for residential and hospitality applications (product supplied less lamp)
- Permanent earth on stirrup bracket for GU10 mains earthing
- 30 degree tilt angle
- Manufactured from high grade die-cast aluminium
- Generous size of terminal housing and 2x1.5mm, + CPC loop-in, loop-out push fit terminals provide an easy and efficient installation
- Option to add Bluetooth and WiFi enabled smart WIZ GU10 lamp

GENERAL INFORMATION	
Wattage	35W
Input	220/240V
Operating Temp	0°C - 25°C
Cut-Out Size	84
Product Weight without Packaging	0.144 kg

TECHNICAL INFORMATION	
Light Source	GU10
Colour / Finish	Black Chrome
IP Rating	IP20
Class Protection	1
Internal / External	Internal
Surface / Recessed / Suspended	Recessed
Warranty (Years)	5
CE Mark	Yes
Diameter	93.5 mm
Height	108 mm
Accessories	ATL/BA

