



Category	Emergency
Application	Ancillary
Specification	Performance

Swift

Swift Bulkhead Maintained / Non-Maintained White
Code: ASWTLED/3M

PRODUCT FEATURES

- Supplied with self-adhesive legend
- Optic design provides optimum performance for escape route lighting
- Screwless gear tray for ease of installation
- Supplied with self-adhesive legend
- Side and rear cable entries
- Viewing distance 17 metres

GENERAL INFORMATION

Wattage	3W
Lumens Delivered	64lm (Emergency), 173lm (Standard)
Beam Angle	105/120
CRI	70
CCT	6500K
Input	220-240V
Operating Temp	0°C - 40°C
Product Weight without Packaging	0.324 kg

TECHNICAL INFORMATION

Light Source	LED
Colour / Finish	White
IP Rating	IP65
Class Protection	1
Internal / External	Internal / External
Surface / Recessed / Suspended	Ceiling, Wall
Lumen Depreciation	L70 50,000h
Warranty (Years)	3
CE Mark	Yes
Height	100 mm
Emergency Output Duration	3 Hr





Category	Emergency
Application	Ancillary
Specification	Performance

Swift

Swift Bulkhead Maintained / Non-Maintained White
Code: ASWTLED/3M

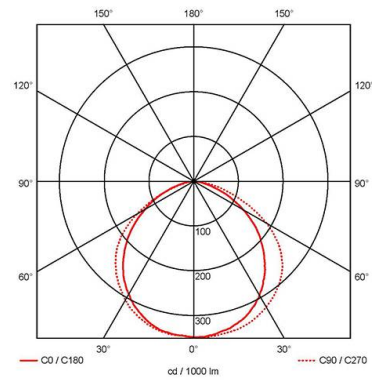
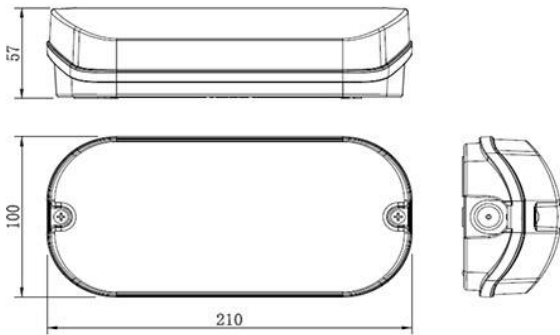

SPARES

ASBP/1

3.6V 600mAh Ni-Cd Replacement Battery