

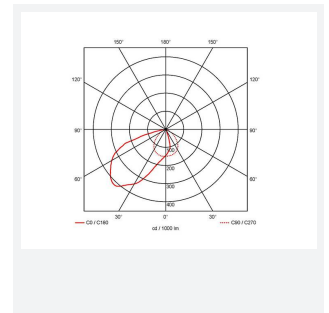

Spirit Asymmetrical

Spirit LED Asymmetrical Projector 4000K
Code: ASPLED/ASY/CW

Category	Feature Lighting
Application	Hospitality, Outdoor, Residential, Retail
Specification	Architectural

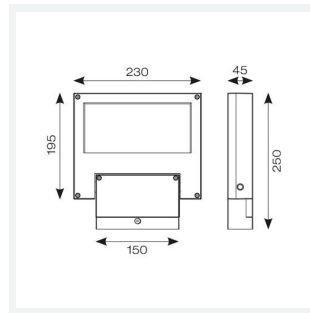
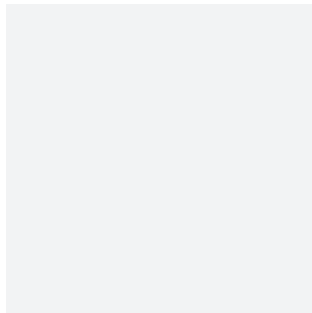
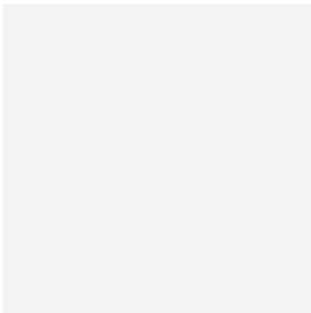

- High performance LED projector light suitable for commercial applications
- Non-dimmable
- External application examples:- Commercial buildings to provide a sufficient wall washer effect for projected facades
- Die-cast aluminium construction with textured graphite finish
- Internal application examples:- Transport hubs, churches and historical buildings amongst other commercial applications. Ideal to improve atmosphere and brighten indoor spaces
- Powered by Tridonic

GENERAL INFORMATION	
Wattage	25
Lumens Delivered	1700lm
Lm/W	71lm/W
Beam Angle	40/100
CRI	80
CCT	4000K
Input	220-240V
Operating Temp	0°C - 25°C
SDCM	3
Energy efficiency class	E
Product Weight without Packaging	2.081 kg

TECHNICAL INFORMATION	
Light Source	LED
Colour / Finish	Graphite
IP Rating	IP66
Class Protection	1
Internal / External	External
Surface / Recessed / Suspended	Floor, Wall
Warranty (Years)	5
CE Mark	Yes
Height	250 mm

