

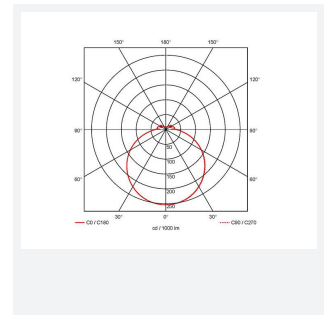

Spektrum

Spektrum CCT Panel Frame Switch Dim Self-Test
Code: ASPELED/60/CCT/DD1/SM3

Category	Commercial Panels
Application	Commercial
Specification	Performance

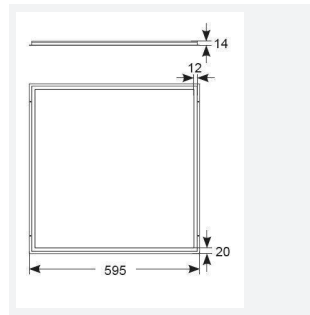
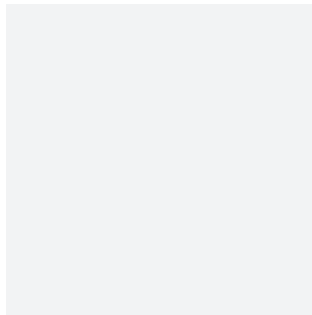
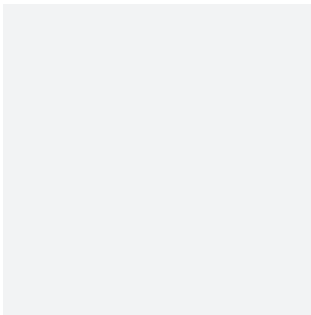

PRODUCT FEATURES

- Minimalist LED panel frame for commercial and architectural applications
- Integral switch allows the installer a choice of 3000K, 4000K and 6500K colour temperature options
- Retains all fire integrity of the ceiling
- Hollow illuminated frame allows installation of standard ceiling panel to sit inside frame and level with grid
- More decorative option for general illumination

GENERAL INFORMATION

Wattage	27W
Lumens Delivered	3000lm (4000K)
Lm/W	112lm/W (4000K)
Beam Angle	125
CRI	80
CCT	3000/4000/6500K
Input	220-240V
Operating Temp	0°C - 45°C
SDCM	6
UGR	20
Cut-Out Size	585x585mm
Product Weight without Packaging	0.01 kg

TECHNICAL INFORMATION

Light Source	LED
Colour / Finish	Aluminium
IP Rating	IP20
Class Protection	2
Internal / External	Internal
Surface / Recessed / Suspended	Recessed
Lumen Depreciation	L70 54,000h
Warranty (Years)	3
CE Mark	Yes

