



Category	Emergency
Application	Ancillary, Commercial, Education, Healthcare, Hospitality, Industrial, Retail
Specification	Performance

Raven

Raven Emergency Downlight Non-Maintained Open Area White
Code: ARALED/OA/3NM/ST



- Recessed Self-test emergency downlight with self-contained inverter and battery pack
- Option of escape route or open area models
- Pre-wired with 150mm rubber insulated cable for ease of installation
- Integral components for fast-fit installation
- High performance optic design
- Up to 15 metres spacing between luminaires

GENERAL INFORMATION	
Wattage	3W
Lumens Delivered	130lm (Emergency)
Beam Angle	45
CRI	70
CCT	6500K
Input	220-240V
Operating Temp	0°C - 40°C
SDCM	6
Cut-Out Size	95mm
Product Weight without Packaging	0.28 kg

TECHNICAL INFORMATION	
Light Source	LED
Colour / Finish	White
IP Rating	IP65
Class Protection	1
Internal / External	Internal
Surface / Recessed / Suspended	Recessed
Lumen Depreciation	L70 50,000h
Warranty (Years)	5
CE Mark	Yes
Diameter	110 mm
Height	98 mm
Emergency Output Duration	3 Hr



Category	Emergency
Application	Ancillary, Commercial, Education, Healthcare, Hospitality, Industrial, Retail
Specification	Performance

Raven

Raven Emergency Downlight Non-Maintained Open Area White
Code: ARALED/OA/3NM/ST

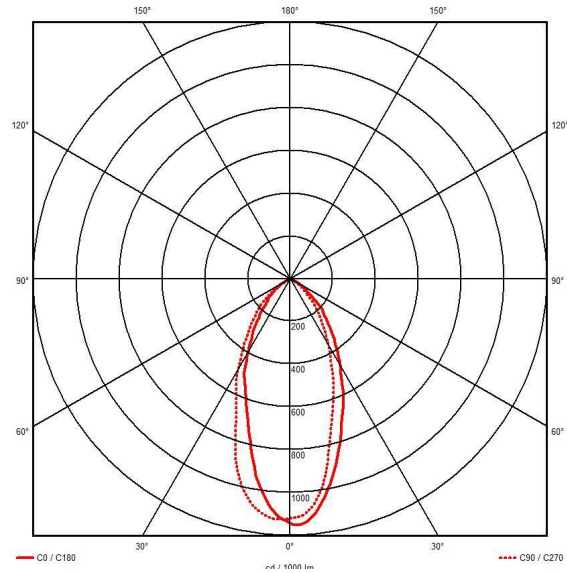
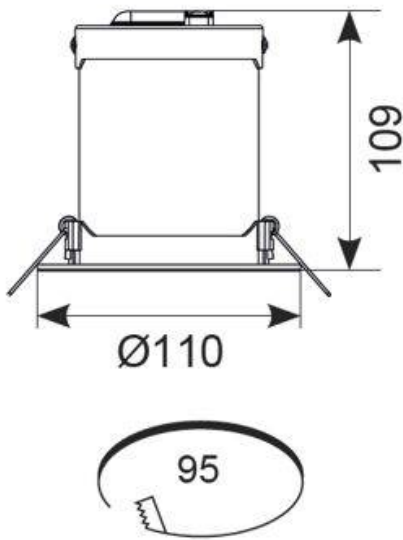

SPARES	
ASBP/14/LI	3.2V 3000mAh Li-FePO4 Replacement Battery