

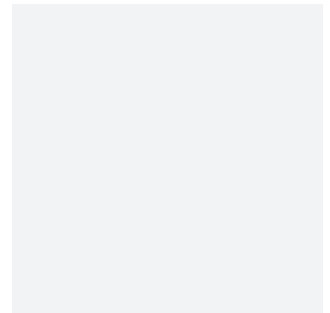

Panel Pod PRO

Panel Pod PRO DALI Emergency
Code: APOD/1/3NM/DA

Application	Ancillary, Commercial, Education, Healthcare, Hospitality, Retail
Specification	Performance

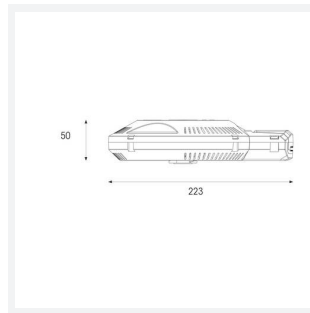

PRODUCT FEATURES

- Integral Self-Test emergency pod DALI to convert any Pace and Endurance. panel to emergency, instantly.
- Simple, quick twist and lock fixing
- Supplied with a pre-wired 1 Metre cable for ease of installation
- Patent Protected. GB 2522285B (United Kingdom)
- LiFePO4 Lithium battery provides improved energy consumption, product reliability and lifetime
- 6 way fast wire plug in connector for speed and ease of installation (APOD/1/3NM/DA only)
- Tri-colour LED shows green for healthy running condition, red/flashing for fault conditions and white for emergency operation
- Patent Protected. EP 2957826B (Europe)

GENERAL INFORMATION

Wattage	3W
Lumens Delivered	190lm
Beam Angle	120
CRI	70
CCT	6000-7000K
Input	220/240V
Operating Temp	0°C to 40°C
SDCM	6
Product Weight without Packaging	0.294 kg

TECHNICAL INFORMATION

Colour / Finish	White
IP Rating	IP20
Class Protection	1
Internal / External	Internal
Warranty (Years)	5
CE Mark	Yes

