

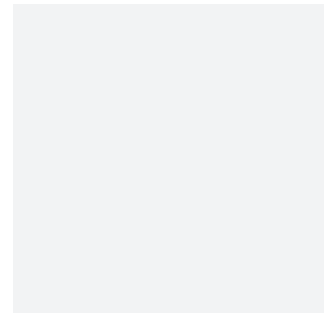

Category	Smart Lighting
Application	Commercial, Hospitality, Retail
Specification	Architectural

## OCTO Indoor Wireless Xpress Smart Switch Black

**Code: AOCTO/XP/WS/B**

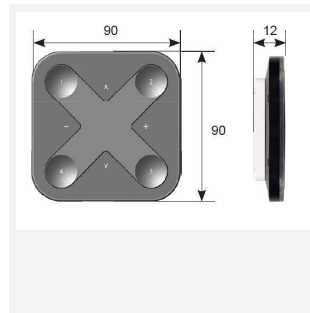
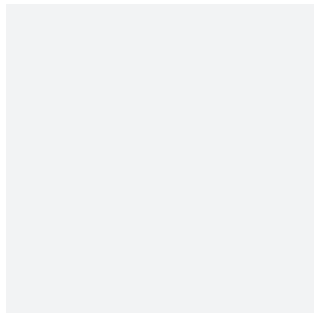
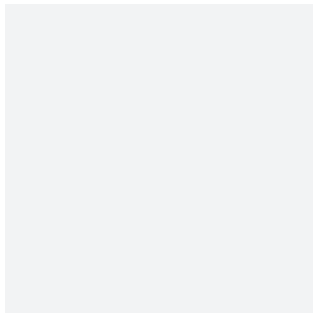

- Bluetooth enabled internal smart switches for use with OCTO Casambi eco-system and suitable for residential and commercial applications
- Settings easily commissioned by a smart device via the Casambi app
- Integrated magnets ensure easy attachment to mounting bracket (mounting bracket supplied with switch)
- Multifunctional 4 way bluetooth enabled smart switch
- Compatible with all other bluetooth OCTO Casambi devices as part of the OCTO Casambi ecosystem
- Range - within one room up to 30 metres line of sight

### GENERAL INFORMATION

Product Weight without Packaging	0.087
----------------------------------	-------

### TECHNICAL INFORMATION

Colour / Finish	Black
IP Rating	IP20
Internal / External	Internal
Surface / Recessed / Suspended	Wall
Warranty (Years)	5
CE Mark	Yes
Height	90 mm

