

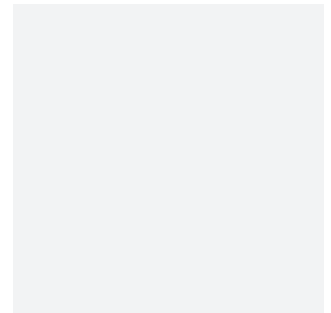

Category	Smart Lighting
Application	Commercial, Hospitality, Retail
Specification	Architectural

OCTO IP65 Wireless Smart Switch

Code: AOCTO/BT/WS/IP65

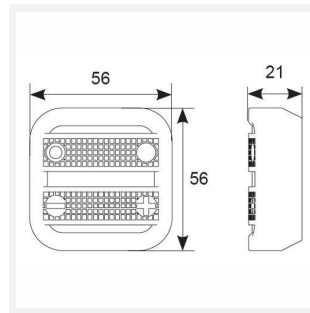
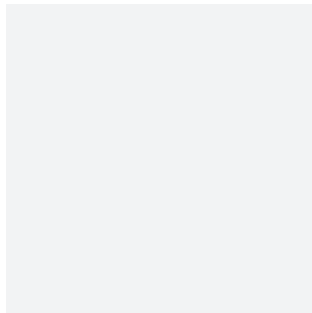
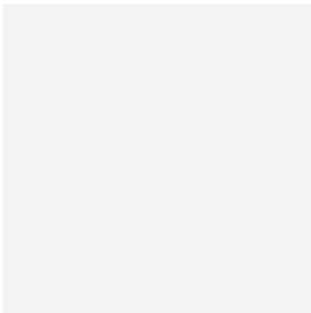

- Bluetooth enabled internal smart switch for use with OCTO Casambi eco-system and suitable for residential and commercial applications
- Compatible with all other bluetooth OCTO Casambi devices as part of the OCTO Casambi ecosystem
- Spill and shock resistant
- Integrated magnet allows it to be stuck on any metallic area
- Wireless soft outdoor remote control
- Magneto-resistive power source
- Advantages of a wireless system, no batteries required maintenance free
- Range - 30 metres

GENERAL INFORMATION

Product Weight without Packaging 0.057

TECHNICAL INFORMATION

Colour / Finish	Grey
IP Rating	IP65
Internal / External	External
Surface / Recessed / Suspended	Wall
Warranty (Years)	5
CE Mark	Yes
Height	56 mm

