

Neptune

Neptune CCT Recessed Modular DSI
Code: ANEPLD/DD2

| | |
|---------------|-----------------------------------|
| Category | Commercial Panels |
| Application | Commercial, Education, Healthcare |
| Specification | Performance |

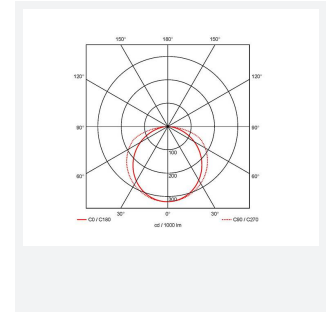
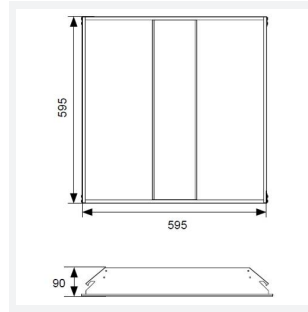

PRODUCT FEATURES

- High performance recessed luminaire Ideal for office or commercial applications
- Powder coated steel construction
- Selectable CCT between 3000K, 4000K and 6000K output
- Powered by Tridonic

| GENERAL INFORMATION | |
|----------------------------------|-----------------|
| Wattage | 35W |
| Lumens Delivered | 3600lm (4000K) |
| Lm/W | 99lm/W (4000K) |
| Beam Angle | 110/130 |
| CRI | 80 |
| CCT | 3000/4000/6000K |
| Input | 220-240V |
| Operating Temp | -20°C - 45°C |
| SDCM | 6 |
| UGR | 20 |
| Cut-Out Size | 575x575mm |
| Product Weight without Packaging | 3.55 kg |

| TECHNICAL INFORMATION | |
|--------------------------------|-------------|
| Light Source | LED |
| Colour / Finish | White |
| IP Rating | IP20 |
| Class Protection | 2 |
| Internal / External | Internal |
| Surface / Recessed / Suspended | Recessed |
| Lumen Depreciation | L80 54,000h |
| Warranty (Years) | 5 |
| CE Mark | Yes |
| Height | 90 mm |

