

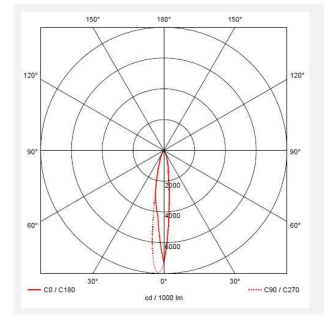

Fresno

Fresno Adjustable Inground 220mm Cool White
Code: AFRWOLED/220/CW

Category	Feature Lighting
Application	Commercial, Education, Healthcare, Hospitality, Outdoor, Residential, Retail
Specification	Architectural

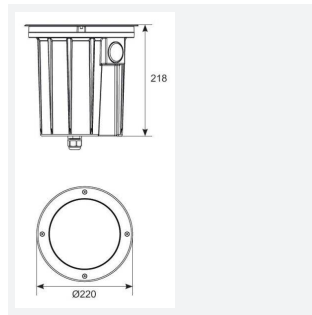
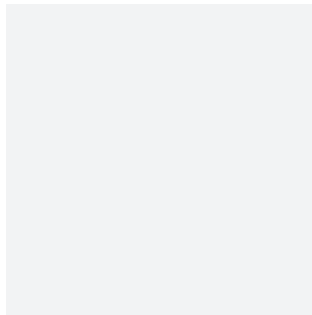
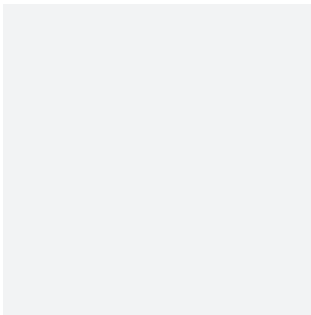

- High performance LED adjustable inground uplight suitable for commercial and hospitality applications
- Supplied c/w installation housing for additional protection and ease of installation
- Static load test to 2000kg; suitable for vehicular and pedestrian traffic
- 304L stainless steel bezel and powder coated aluminium housing
- Integral driver and pre-wired with 2 metres of rubber insulated cable
- Non-dimmable

GENERAL INFORMATION	
Wattage	20W
Lumens Delivered	1100lm
Lm/W	54lm/W
Beam Angle	20
CRI	80
CCT	4000K
Input	220-240V
Operating Temp	-20°C - 40°C
SDCM	3
Product Weight without Packaging	4.731 kg

TECHNICAL INFORMATION	
Light Source	LED
Colour / Finish	Stainless Steel
IP Rating	IP67
Class Protection	1
Internal / External	External
Surface / Recessed / Suspended	Recessed
Lumen Depreciation	L80 50,000h
Warranty (Years)	5
CE Mark	Yes
Diameter	220 mm

