



@ansell_lighting



ansellighting



Ansell Lighting



ansell_lighting

Endurance 600x600

Endurance TP(a) 600x600 Panel OCTO Smart
Code: AERMLED2/60/WW/OCTO

Category	Commercial Panels
Application	Ancillary, Commercial, Education, Healthcare, Retail
Specification	Performance

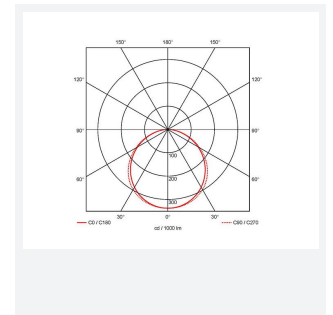
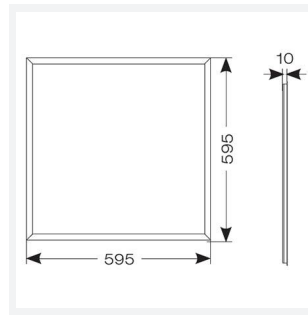
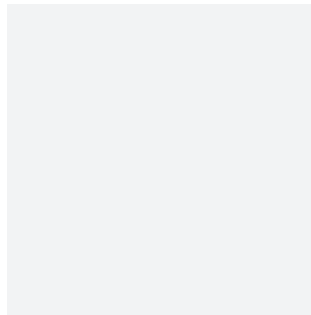
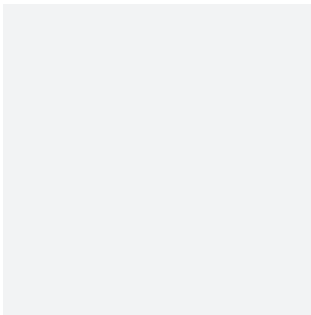

PRODUCT FEATURES

- Edge lit LED panel suitable for education, commercial and ancillary area applications
- White anodised aluminium frame for visual compatibility with ceiling grid
- TPa as standard
- Self-Test Panel Pod and Sensor Pod compatible
- Cool white, warm white and daylight options
- Surface mounting frame option
- Switch Dim, DALI and 0-10V dimming capability using the multi dimmable driver accessories ADDIM/30/MC

GENERAL INFORMATION

Wattage	30W
Lumens Delivered	2900lm
Lm/W	96lm/W
Beam Angle	110
CRI	80
CCT	3000K
Input	220/240V
Operating Temp	-20°C - 40°C
SDCM	4
UGR	21
Cut-Out Size	585x585mm
Product Weight without Packaging	2.256 kg

TECHNICAL INFORMATION

Light Source	LED
Colour / Finish	White
IP Rating	IP44
Class Protection	2
Internal / External	Internal
Surface / Recessed / Suspended	Ceiling, Recessed, Suspended
Lumen Depreciation	L80 76,000h
Warranty (Years)	5
CE Mark	Yes
Accessories	AERMLED/SK, AERMLED/60/SMF, AERMLED/60/CGCB/KIT, APRK/60

