

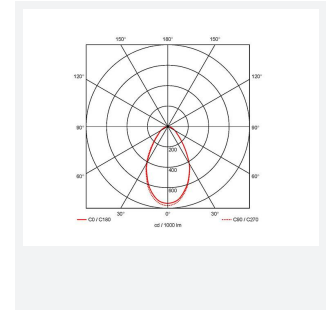

Deco

Deco High Bay 2 Polycarbonate Refractor Code: ADHBLD2/PC

Category	High/Low Bay
Application	Commercial, Education, Healthcare, Industrial, Retail
Specification	Performance

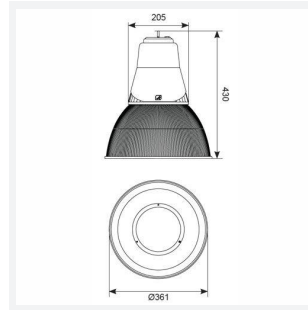

PRODUCT FEATURES

- Decorative modern LED CCT selectable pendant suitable for industrial, commercial and retail applications
- Supplied with either polycarbonate refractor or aluminium reflector
- Matt grey textured powder coated finish

GENERAL INFORMATION	
Wattage	96W
Lumens Delivered	10500lm (4000K)
Lm/W	116lm/W (4000K)
Beam Angle	65
CRI	80
CCT	3000/4000K
Input	220/240V
Operating Temp	-20°C - 25°C
SDCM	5
Product Weight without Packaging	2.837 kg

TECHNICAL INFORMATION	
Light Source	LED
Colour / Finish	Graphite
IP Rating	IP20
Class Protection	1
Internal / External	Internal
Surface / Recessed / Suspended	Suspended
Lumen Depreciation	L70 54,000h
Warranty (Years)	5
CE Mark	Yes
Diameter	361 mm
Height	430 mm
Accessories	ADHBLD/PC/BC, ADHBLD/SK

