



# Avio

Avio Bollard Half Shield Graphite

Code: AAVIO/HS/GR

Category	Bollards
Application	Hospitality, Residential, Retail
Specification	Architectural

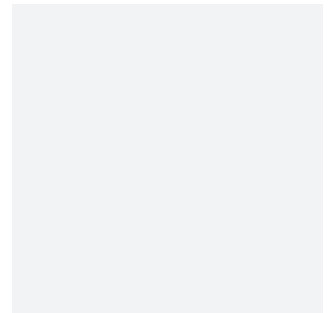
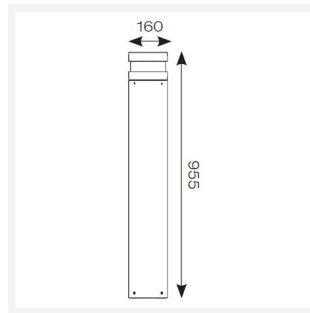
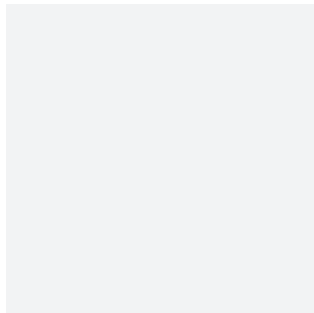
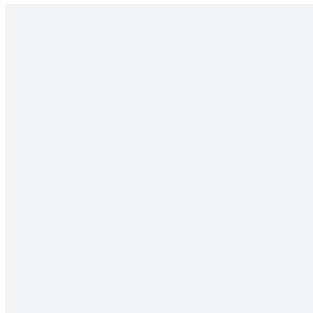

- Avio bollard accessory

## GENERAL INFORMATION

Product Weight without Packaging 0.137

## TECHNICAL INFORMATION

Colour / Finish	Graphite
Internal / External	External
Warranty (Years)	5

