

## IP65 PIR SENSOR - CEILING/RECESS MOUNT

NET-51-11-05



### Features & Benefits

- Uses infrared technology to detect movement
- Built-in photocell to detect between day and night
- Time Delay function is extended with every detection of movement
- Cut-out size Ø62mm

### Key Data

<b>Power</b>	0.5W
<b>IP Rating</b>	IP65
<b>Dimensions</b>	Ø75.65 x 35mm
<b>Warranty</b>	5 Years (Registration Required)

### NET LED Lighting

Buckingham Business Park, 300 Anderson Road,  
Swavesey, Cambridge, CB24 4UQ

T: 01223 851505 | [sales@netled.co.uk](mailto:sales@netled.co.uk) | [www.netled.co.uk](http://www.netled.co.uk)



**ORDER BY 6PM**  
FOR NEXT DAY DELIVERY

## Technical Specifications

Input Voltage (AC)	220-240V
Operating Temp.	-20°C to +40°C
Manufacturer	Sealite Co. Ltd.
Lux Levels	<3lux - 2000lux
Max. Detection Distance	8m
Max. Load	600W
Power Frequency	50/60Hz
Cut-Out Size	Ø62mm
Max. Mounting Height	4
Housing Colour	White
Housing Material	Polycarbonate
Detection Angle	360°
Duration	10s - 30min
Max. Detection Area	8m

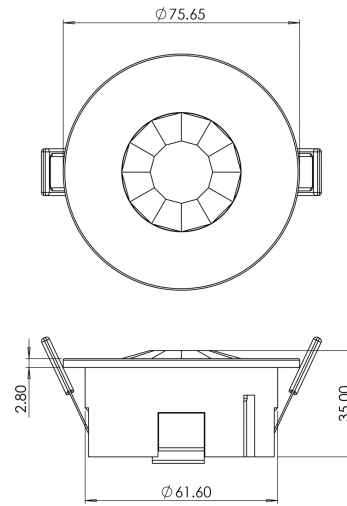

## Other Options

Description	
NET-51-11-05	IP65 PIR Sensor - Ceiling/Recess Mount

### NET LED Lighting

Buckingham Business Park, 300 Anderson Road,  
Swavesey, Cambridge, CB24 4UQ



**ORDER BY 6PM**  
FOR NEXT DAY DELIVERY

T: 01223 851505 | sales@netled.co.uk | www.netled.co.uk