

ARTERIO RS

FREEPORT MIRROR

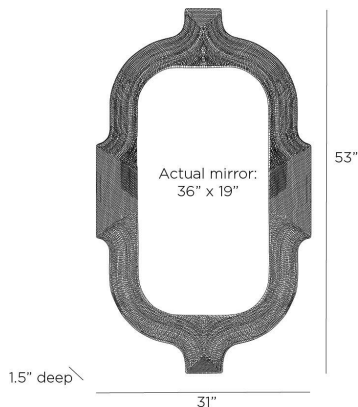

WMS05
Tobacco Stained, Abaca

We gave the architecturally inspired Freeport an edge by wrapping it with tobacco-stained abaca rope. With a silhouette inspired by Indian architecture, it lends the perfect mix of graphic forms and tactile textures to any rustic or coastal space. Designed to be displayed both vertically and horizontally. Secured at the back with a cleat attachment. Finish will vary.

APPEARANCE

Materials	Abaca, Mirror
Finishes	Tobacco Stained, Plain
Finish Will Vary	Yes
Top Coat/Sealant	Yes

DIMENSIONS

Overall	W: 31 in x D: 1.5 in x H: 53 in
Actual Mirror	W: 19 in x H: 36 in

SHIPPING

Product Weight	36.3 lbs
Gross Weight 1	46.0 lbs
Shipping Box 1	W: 34.0 in x D: 5.5 in x H: 57.0 in

ADDITIONAL INFO

Features	T-Screw Hardware Included
Hanger Position	Vertical & Horizontal

CONTRACT

Contract Suitability	Contract Suitable As Is
----------------------	-------------------------