

ARTERIO RS

EQUINOX LAMP

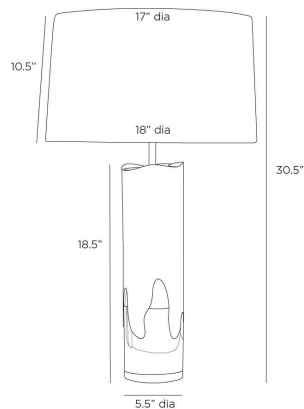

PTC46-SH049
Clear, Crystal

The alchemy of melted metal in one sleek column lamp. Crystal is adorned in flowing antique brass, with an undulating edge that draws the eye. Matching antique brass hardware and off-white microfiber drum shade.

APPEARANCE

Materials	Crystal, Steel, Microfiber, Cotton
Finishes	Clear, Antique Brass, Off-White, Off-White
Finish Will Vary	No
Top Coat/Sealant	No

DIMENSIONS

Overall	Dia: 18.0 in x H: 30.5 in
Foot Print	Dia: 5.5 in
Body	Dia: 5.5 in x H: 18.5 in
Finial	Dia: 1 in x H: 1 in
Shade Top	Dia: 17.0 in
Shade Side	H: 10.5 in
Shade Bottom	Dia: 18.0 in
Harp Size	H: 9 in
Neck	Dia: 0.5 in x H: 2 in

WIRING

Wire Rating	Indoor Only
Cord	9 FT, Taupe Fabric, SPT-2
Socket	1, Type A - E26
Suggested Bulb Type	A19
Switch	At Socket, 3-Way Rotary
Maximum Wattage	150.0
Voltage	110-120 V

CERTIFICATIONS & COMPLIANCY

Certifications	Middle East, European Union, United Kingdom, Australia, Mexico, United States, Canada
Compliance	RoHS, UL/ETL, CB

SHIPPING

Product Weight	25.4 lbs
Gross Weight 1	30.0 lbs
Gross Weight 2	5.0 lbs
Shipping Box 1	W: 10.0 in x D: 10.0 in x H: 28.0 in
Shipping Box 2	W: 19.3 in x D: 19.3 in x H: 35.0 in

CONTRACT

Contract Suitability	Contract Suitable As Is
Tilt Test Degrees	10 Degrees