

ARTERIOS

DURHAM CHAIR

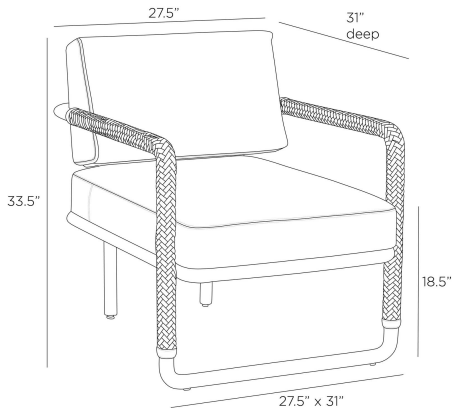

FRI15
Cognac, Leather

The classic leather club chair, updated with modern open arms and pieced details. Tactile braided leather of a rich cognac hue on each arm complements its sturdy mid-century lines. An open frame of blackened bronze stainless steel makes this generously scaled seat both airy and easy to place. Finish will vary.

APPEARANCE

| | |
|------------------|--------------------------|
| Materials | Leather, Stainless Steel |
| Finishes | Cognac, Blackened Bronze |
| Finish Will Vary | Yes |
| Top Coat/Sealant | No |

DIMENSIONS

| | |
|---------------------|--------------------------------------|
| Overall | W: 27.5 in x D: 31 in x H: 33.5 in |
| Foot Print | W: 27.5 in x D: 31 in |
| Arm | W: 2 in x D: 31 in x H: 2 in |
| Back Leg | Dia: 2.0 in x H: 12 in |
| Front Leg | W: 25.5 in x D: 2 in x H: 12 in |
| Seat Back | W: 24 in x D: 5.5 in x H: 26 in |
| Seat | W: 23.5 in x D: 30.5 in x H: 18.5 in |
| Diagonal Dimensions | W: 46 in |

SHIPPING

| | |
|-----------------------|--|
| Shipping Requirements | Truck Ship |
| Product Weight | 43.3 lbs |
| Gross Weight 1 | 60.42 lbs |
| Shipping Box 1 | W: 34.25 in x D: 30.0 in x H: 35.45 in |

ADDITIONAL INFO

Disclaimers
This piece is made with genuine leather. The variations in color are a natural characteristic of leather and may increase over time, adding to the individuality of your item. Please keep this away from prolonged intense sunlight, heat and humidity.

| | |
|---------------------------|---------------------------|
| Fabric Certification | NFPA-260, TB117-2013 |
| Fabric Composition | 100% Leather |
| Fabric Cleaning Code | Leather Cleaner |
| Reupholstery Requirements | 126 Square Feet 7 Yards |
| Base/Foot Type | Glides |

CONTRACT

| | |
|------------------------------|----------------------------|
| Contract Suitability | Contract Suitable As Is |
| Contract Textile Suitability | High Traffic/Public Spaces |

REPLACEMENT PARTS

FRI12FOOT